

FUJIFILM

DIGITAL CAMERA

X-T200

Owner's Manual

Introduction

Thank you for your purchase of this product. Be sure that you have read this manual and understood its contents before using the camera. Keep the manual where it will be read by all who use the product.

For the Latest Information

The latest versions of the manuals are available from:

<http://fujifilm-dsc.com/en/manual/>



The site can be accessed not only from your computer but also from smartphones and tablets. It also contains information on the software license.



For information on firmware updates, visit:

<https://fujifilm-x.com/support/download/firmware/>



Chapter Index

Menu List	iv
1 Before You Begin	1
2 First Steps	25
3 Basic Photography and Playback	39
4 Movie Recording and Playback	45
5 Taking Photographs	51
6 The Shooting Menus	97
7 Playback and the Playback Menu	131
8 The Setup Menus	155
9 Shortcuts	179
10 Peripherals and Optional Accessories	191
11 Connections	197
12 Technical Notes	209





Menu List









Camera menu options are listed below.

Shooting Menus

Adjust settings when shooting photos or movies.

 See page 97 for details.





 IMAGE QUALITY SETTING		 AF/MF SETTING		
1/2	IMAGE SIZE	98	FOCUS AREA	105
	IMAGE QUALITY	99	FOCUS MODE	105
	FILM SIMULATION	100	AF MODE	105
	PORTRAIT ENHANCER LV	101	NUMBER OF FOCUS POINTS	106
	BRIGHT MODE	101	PRE-AF	106
	DYNAMIC RANGE	102	AF ILLUMINATOR	106
	WHITE BALANCE	103	FACE/EYE DETECTION SETTING	107
	HIGHLIGHT TONE	103	AF+MF	108
	SHADOW TONE	103	MF ASSIST	108
	COLOR	103	FOCUS CHECK	109
2/2	SHARPNESS	103	2/2 INTERLOCK SPOT AE & FOCUS AREA	109
	NOISE REDUCTION	104	RELEASE/FOCUS PRIORITY	109
	LONG EXPOSURE NR	104	TOUCH SCREEN MODE	109
	COLOR SPACE	104		

 SHOOTING SETTING 	
	SCENE POSITION 110
	ADVANCED FILTER 110
	CLARITY FILTER SETTING 110
1/2	INTERVAL TIMER SHOOTING 111
	TIME-LAPSE MOVIE MODE 113
	AE BKT SETTING 114
	FILM SIMULATION BKT 115
	LIGHT TRAIL SHOOTING SETTING 115
2/2	SELF-TIMER 116
	PHOTOMETRY 116
	SHUTTER TYPE 117
	IS MODE 118
	ISO 118
	MOUNT ADAPTOR SETTING 120
	TOUCH ZOOM 122
	WIRELESS COMMUNICATION 122
 MOVIE SETTING 	
	MOVIE MODE 124
	HDR MOVIE MODE 125
	DIGITAL GIMBAL 125
1/2	DIGITAL IMAGE STABILIZER 125
	FULL HD HIGH SPEED REC 126
	COUNTDOWN VIDEO RECORDING 126
	 FOCUS MODE 126
	MOVIE AF MODE 127
	 ISO 127
	HDMI OUTPUT INFO DISPLAY 127
2/2	4K MOVIE OUTPUT 128
	HDMI REC CONTROL 128
	AUDIO SETTING 129
	MIC/REMOTE RELEASE 130
 FLASH SETTING 	
	FLASH MODE 123
	FLASH COMPENSATION 123
	RED EYE REMOVAL 123

Playback Menu

Adjust playback settings.

 See page 137 for details.

 PLAY BACK MENU		 PLAY BACK MENU	
RAW CONVERSION	:137	IMAGE TRANSFER ORDER	:147
ERASE	:139	WIRELESS COMMUNICATION	:148
CROP	:141	SLIDE SHOW	:148
RESIZE	:142	PHOTOBOOK ASSIST	:149
MOVIE TRIMMING	:143	PC AUTO SAVE	:150
PROTECT	:144	PRINT ORDER (DPOF)	:151
IMAGE ROTATE	:145	instax PRINTER PRINT	:152
RED EYE REMOVAL	:146	DISP ASPECT	:153

Setup Menu

Adjust basic camera settings.

 See page 155 for details.









USER SETTING		BUTTON/DIAL SETTING	
FORMAT	156	FOCUS LEVER SETTING	168
DATE/TIME	157	EDIT/SAVE QUICK MENU	169
TIME DIFFERENCE	157	FUNCTION (Fn) SETTING	169
 言語/LANG.	158	SHOOT WITHOUT LENS	169
MY MENU SETTING	158	FOCUS RING	169
SENSOR CLEANING	158	TOUCH SCREEN SETTING	170
SOUND & FLASH	158		
RESET	159	POWER MANAGEMENT	
		AUTO POWER OFF	171
SOUND SETTING		PERFORMANCE	171
AF BEEP VOL.	160	SAVE DATA SETTING	
SELF-TIMER BEEP VOL.	160	FRAME NO.	172
OPERATION VOL.	160	SAVE ORG IMAGE	173
SHUTTER VOLUME	161	EDIT FILE NAME	173
SHUTTER SOUND	161	DATE STAMP	173
PLAYBACK VOLUME	161		
SCREEN SETTING		CONNECTION SETTING	
EVF BRIGHTNESS	162	Bluetooth SETTINGS	174
EVF COLOR	162	PC AUTO SAVE	175
LCD BRIGHTNESS	162	instax PRINTER CONNECTION SETTING	176
LCD COLOR	162	USB IMAGE TRANSFER SETTING	176
$\frac{1}{2}$ IMAGE DISP.	163	GENERAL SETTINGS	177
AUTOROTATE DISPLAYS	163	INFORMATION	177
PREVIEW EXP./WB IN MANUAL MODE	163	RESET WIRELESS SETTING	177
NATURAL LIVE VIEW	164		
FRAMING GUIDELINE	164		
AUTOROTATE PB	165		
FOCUS SCALE UNITS	165		
$\frac{2}{2}$ DISP. CUSTOM SETTING	165		
LARGE INDICATORS MODE(EVF)	166		
LARGE INDICATORS MODE(LCD)	166		
LARGE INDICATORS DISP. SETTING	167		



Table of Contents

Introduction.....	ii
For the Latest Information.....	ii
Menu List.....	iv
Shooting Menus.....	iv
Playback Menus.....	vi
Setup Menus.....	vii
Supplied Accessories.....	xvii
About This Manual.....	xviii
Symbols and Conventions.....	xviii
Terminology.....	xviii

1 Before You Begin **1**

Parts of the Camera.....	2
The Mode Dial.....	4
The Focus Stick (Focus Lever).....	5
 (drive) button.....	5
The Command Dials.....	6
Fn (function) dial.....	7
The Indicator Lamp.....	8
The LCD Monitor.....	9
Focusing the Viewfinder.....	9
Camera Displays.....	10
The Standard Shooting Display.....	10
The Touch Menu Display.....	12
Choosing a Display Mode.....	13
Adjusting Display Brightness.....	14
Display Rotation.....	14
The DISP/BACK Button.....	15
Customizing the Standard Display.....	16
Using the Menus.....	18
Touch Screen Mode.....	19
Shooting Touch Controls.....	19
Playback Touch Controls.....	23

2	First Steps	25
	Attaching the Shoulder Strap.....	26
	Attaching a Lens.....	27
	Inserting the Battery and a Memory Card	28
	Compatible Memory Cards	31
	Charging the Battery	32
	Turning the Camera On and Off	34
	Checking the Battery Level.....	35
	Basic Setup	36
	Choosing a Different Language.....	38
	Changing the Time and Date.....	38
3	Basic Photography and Playback	39
	Taking Photographs.....	40
	Viewing Pictures.....	42
	Deleting Pictures.....	43
4	Movie Recording and Playback	45
	Recording Movies	46
	Adjusting Movie Settings.....	48
	Viewing Movies.....	49
5	Taking Photographs	51
	Choosing a Shooting Mode	52
	SR+ ADVANCED SR AUTO	52
	Program AE (P).....	53
	Shutter-Priority AE (S).....	54
	Aperture-Priority AE (A).....	56
	Manual Exposure (M).....	57
	PANORAMA.....	60
	SP SCENE POSITION / ▲/🏃/🕒	63
	Adv. ADVANCED FILTER	66
	Autofocus.....	68
	Focus Mode.....	69
	Autofocus Options (AF Mode).....	71
	Focus-Point Selection.....	73
	Manual Focus.....	77
	Checking Focus.....	78

Exposure Compensation	79
Focus/Exposure Lock	80
The Function Buttons	80
White Balance	81
WHITE BALANCE	82
Custom White Balance	83
K : Color Temperature	84
Using the Self Timer	85
2 SEC/10 SEC	86
FACE AUTO SHUTTER	86
SMILE	87
BUDDY	87
GROUP	88
Bracketing	89
AE BKT	90
ISO ISO BKT	90
F FILM SIMULATION BKT	90
WB WHITE BALANCE BKT	90
DR DYNAMIC RANGE BKT	91
HDR HDR	91
Continuous Shooting (Burst Mode)	92
Using the Flash	94
Self-Portraits (Selfies)	96

6 The Shooting Menus	97
IMAGE QUALITY SETTING	98
IMAGE SIZE.....	98
IMAGE QUALITY	99
FILM SIMULATION.....	100
PORTRAIT ENHANCER LV.....	101
BRIGHT MODE.....	101
DYNAMIC RANGE.....	102
WHITE BALANCE.....	103
HIGHLIGHT TONE	103
SHADOW TONE.....	103
COLOR.....	103
SHARPNESS.....	103
NOISE REDUCTION.....	104
LONG EXPOSURE NR.....	104
COLOR SPACE	104
AF/MF SETTING	105
FOCUS AREA	105
FOCUS MODE.....	105
AF MODE.....	105
NUMBER OF FOCUS POINTS	106
PRE-AF.....	106
AF ILLUMINATOR.....	106
FACE/EYE DETECTION SETTING	107
AF+MF	108
MF ASSIST	108
FOCUS CHECK.....	109
INTERLOCK SPOT AE & FOCUS AREA.....	109
RELEASE/FOCUS PRIORITY	109
TOUCH SCREEN MODE.....	109
SHOOTING SETTING	110
SCENE POSITION.....	110
ADVANCED FILTER.....	110
CLARITY FILTER SETTING	110
INTERVAL TIMER SHOOTING.....	111
TIME-LAPSE MOVIE MODE.....	113

AE BKT SETTING	114
FRAMES/STEP SETTING.....	114
1 FRAME/CONTINUOUS	114
SEQUENCE SETTING	114
FILM SIMULATION BKT.....	115
LIGHT TRAIL SHOOTING SETTING	115
Long Exposure setting	115
RELEASE TYPE	115
SELF-TIMER.....	116
PHOTOMETRY.....	116
SHUTTER TYPE	117
IS MODE	118
ISO.....	118
MOUNT ADAPTOR SETTING	120
TOUCH ZOOM.....	122
WIRELESS COMMUNICATION	122
FLASH SETTING.....	123
FLASH MODE.....	123
FLASH COMPENSATION.....	123
RED EYE REMOVAL	123
MOVIE SETTING	124
MOVIE MODE.....	124
HDR MOVIE MODE	125
DIGITAL GIMBAL.....	125
DIGITAL IMAGE STABILIZER	125
FULL HD HIGH SPEED REC.....	126
COUNTDOWN VIDEO RECORDING	126
📹 FOCUS MODE.....	126
MOVIE AF MODE	127
📹 ISO.....	127
HDMI OUTPUT INFO DISPLAY.....	127
4K MOVIE OUTPUT	128
HDMI REC CONTROL.....	128
AUDIO SETTING	129
MIC/REMOTE RELEASE.....	130

7 Playback and the Playback Menu **131**

The Playback Display	132
The DISP/BACK Button	133
Viewing Pictures	135
Playback Zoom	136
Multi-Frame Playback.....	136
The Playback Menu	137
RAW CONVERSION	137
ERASE.....	139
CROP	141
RESIZE.....	142
MOVIE TRIMMING	143
PROTECT	144
IMAGE ROTATE	145
RED EYE REMOVAL	146
IMAGE TRANSFER ORDER.....	147
WIRELESS COMMUNICATION	148
SLIDE SHOW.....	148
PHOTOBOOK ASSIST	149
PC AUTO SAVE.....	150
PRINT ORDER (DPOF).....	151
instax PRINTER PRINT	152
DISP ASPECT	153

8 The Setup Menus **155**

USER SETTING	156
FORMAT	156
DATE/TIME.....	157
TIME DIFFERENCE	157
言語/LANG.	158
MY MENU SETTING.....	158
SENSOR CLEANING	158
SOUND & FLASH.....	158
RESET	159

SOUND SETTING	160
AF BEEP VOL.....	160
SELF-TIMER BEEP VOL.....	160
OPERATION VOL.....	160
SHUTTER VOLUME.....	161
SHUTTER SOUND.....	161
PLAYBACK VOLUME.....	161
SCREEN SETTING	162
EVF BRIGHTNESS.....	162
EVF COLOR.....	162
LCD BRIGHTNESS.....	162
LCD COLOR.....	162
IMAGE DISP.....	163
AUTOROTATE DISPLAYS.....	163
PREVIEW EXP/WB IN MANUAL MODE.....	163
NATURAL LIVE VIEW.....	164
FRAMING GUIDELINE.....	164
AUTOROTATE PB.....	165
FOCUS SCALE UNITS.....	165
DISP. CUSTOM SETTING.....	165
LARGE INDICATORS MODE(EVF).....	166
LARGE INDICATORS MODE(LCD).....	166
LARGE INDICATORS DISP. SETTING.....	167
BUTTON/DIAL SETTING	168
FOCUS LEVER SETTING.....	168
EDIT/SAVE QUICK MENU.....	169
FUNCTION (Fn) SETTING.....	169
SHOOT WITHOUT LENS.....	169
FOCUS RING.....	169
TOUCH SCREEN SETTING.....	170
POWER MANAGEMENT	171
AUTO POWER OFF.....	171
PERFORMANCE.....	171

SAVE DATA SETTING	172
FRAME NO.	172
SAVE ORG IMAGE	173
EDIT FILE NAME.....	173
DATE STAMP	173
CONNECTION SETTING	174
Bluetooth SETTINGS.....	174
PC AUTO SAVE.....	175
instax PRINTER CONNECTION SETTING	176
USB IMAGE TRANSFER SETTING	176
GENERAL SETTINGS.....	177
INFORMATION.....	177
RESET WIRELESS SETTING	177
9 Shortcuts	179
Shortcut Options.....	180
MY MENU	181
MY MENU SETTING	181
The Quick Menu	183
The Quick Menu Display	183
Viewing and Changing Settings.....	184
Editing the Quick Menu.....	185
Function Controls	186
The Function Buttons.....	186
The Function Dial.....	188
Touch Function Buttons	189
10 Peripherals and Optional Accessories	191
Lenses	192
Lens Parts.....	192
Power Zoom	193
Removing Lens Caps	193
Lenses with Lens Hoods.....	194
Lenses with Aperture Rings.....	194
Lenses with O.I.S. Switches.....	195
Manual Focus Lenses.....	195
Lens Care.....	196

11	Connections	197
	HDMI Output	198
	Connecting to HDMI Devices	198
	Shooting.....	199
	Playback.....	199
	Wireless Connections (Bluetooth®, Wireless LAN/Wi-Fi)	200
	Smartphones and Tablets: FUJIFILM Camera Remote	200
	Copying Pictures to a Computer: PC AutoSave	202
	Connecting via USB.....	203
	Connecting to Computers.....	203
	Copying Pictures to a Computer.....	205
	Connecting to Smartphones.....	205
	instax SHARE Printers	208
	Establishing a Connection	208
	Printing Pictures.....	208
12	Technical Notes	209
	Accessories from Fujifilm.....	210
	Software from Fujifilm.....	212
	FUJIFILM Camera Remote	212
	FUJIFILM PC AutoSave.....	212
	Capture One Express Fujifilm	212
	RAW FILE CONVERTER EX.....	212
	For Your Safety	213
	Product Care	227
	Cleaning the Image Sensor	228
	Firmware Updates.....	229
	Checking the Firmware Version.....	229
	Troubleshooting.....	230
	Warning Messages and Displays	239
	Memory Card Capacity	243
	Specifications	244

Supplied Accessories

The following are included with the camera:

- NP-W126S rechargeable battery
- Body cap
- USB cable
- Headphone adapter
- Shoulder strap
- *Basic Manual*





- If you purchased a lens kit, check that a lens is included.
- The headphone adapter converts the USB Type-C connector to a ø3.5 mm headphone jack.

About This Manual

This manual contains instructions for your FUJIFILM X-T200 digital camera. Be sure you have read and understood its contents before proceeding.

Symbols and Conventions

The following symbols are used in this manual:

-  Information that should be read to prevent damage to the product.
-  Additional information that may be helpful when using the product.
-  Pages on which related information may be found.

Menus and other text in the displays are shown in **bold**. Illustrations are for explanatory purposes only; drawings may be simplified, while photographs are not necessarily taken with the model of camera described in this manual.

Terminology

The optional SD, SDHC, and SDXC memory cards the camera uses to store pictures are referred to as “memory cards”. The electronic viewfinder may be referred to as the “EVF” and the LCD monitor as the “LCD”.

Before You Begin



Parts of the Camera

The parts of the camera are listed below.

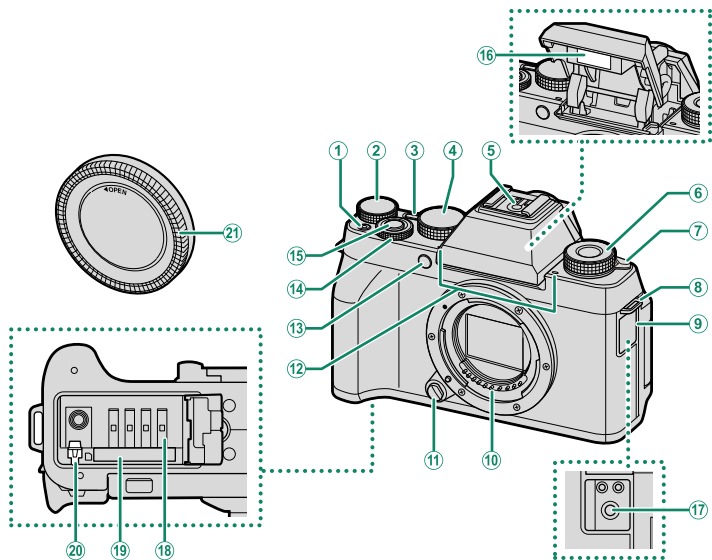

- | | | | | | |
|----|---------------------------------|------------|----|---|------------|
| 1 | ● (movie recording) button..... | 46 | 13 | AF-assist illuminator..... | 40, 106 |
| 2 | Rear command dial..... | 6 | | Self-timer lamp..... | 85 |
| 3 | ON/OFF button..... | 34 | 14 | Front command dial..... | 6 |
| 4 | Mode dial..... | 4, 40, 52 | 15 | Shutter button..... | 41 |
| 5 | Hot shoe..... | 95, 211 | 16 | Flash..... | 94, 123 |
| 6 | Fn (function) dial..... | 7, 188 | 17 | Microphone/remote release connector
($\varnothing 3.5$ mm)..... | 46, 55, 59 |
| 7 | ⚡ (flash pop-up) lever..... | 94 | 18 | Battery chamber..... | 28 |
| 8 | Strap eyelet..... | 26 | 19 | Memory card slot..... | 28 |
| 9 | Connector cover..... | 46, 55, 59 | 20 | Battery latch..... | 30 |
| 10 | Lens signal contacts..... | 27, 192 | 21 | Body cap..... | 27 |
| 11 | Lens release button..... | 27 | | | |
| 12 | Microphone..... | 46 | | | |

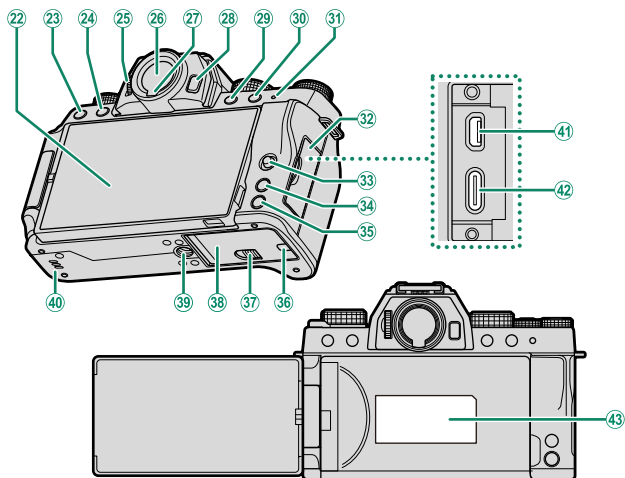

- | | | | | | |
|----|--------------------------------------|-----------------------|----|--|------------------|
| 22 | Vari-angle LCD monitor..... | 9, 10, 13, 14, 15 | 31 | Indicator lamp..... | 8 |
| | Touch screen | 19, 170 | 32 | Connector cover..... | 32, 198 |
| 23 | (drive) button..... | 5, 89, 92 | 33 | Focus stick (focus lever)..... | 5 |
| | (delete) button (playback mode)..... | 43 | 34 | MENU/OK button..... | 18, 97, 137, 155 |
| 24 | (playback) button..... | 42 | 35 | DISP (display)/ BACK button..... | 15, 133 |
| 25 | Diopter adjustment control..... | 9 | 36 | Cable channel cover for DC coupler | |
| 26 | Electronic viewfinder (EVF)
..... | 9, 10, 13, 14, 15, 19 | 37 | Battery-chamber cover latch..... | 28 |
| 27 | Eye sensor..... | 13 | 38 | Battery-chamber cover..... | 28 |
| 28 | VIEW MODE button..... | 13 | 39 | Tripod mount | |
| 29 | Fn1 button..... | 186 | 40 | Speaker..... | 49, 161 |
| 30 | Fn2 button..... | 186 | 41 | HDMI Micro connector (Type D)..... | 198 |
| | | | 42 | USB connector (Type-C)..... | 32, 203 |
| | | | 43 | Serial number plate..... | see below |

Do not remove the serial number plate, which provides the FCC ID, KC mark, CMIIT ID, serial number, and other important information.

The Mode Dial

To select a shooting mode, rotate the dial until the icon for the desired mode aligns with the index.

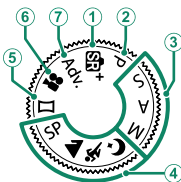

Mode	Description	
① SR+ (ADVANCED SR AUTO)	The camera automatically optimizes settings to the scene.	52
② P (PROGRAM AE)	Aperture and shutter speed can be adjusted using program shift.	53
③ S (SHUTTER PRIORITY AE) A (APERTURE PRIORITY AE) M (MANUAL)	Select for full control over camera settings, including aperture (M and A) and/or shutter speed (M and S).	54 56 57
④ SP (SCENE POSITION) ▲/📷/☾	Choose a scene suited to the subject or shooting conditions and let the camera do the rest.	63
⑤ (PANORAMA)	Follow an on-screen guide to create a panorama.	60
⑥ (MOVIE)	Record movies.	46
⑦ Adv. (ADVANCED FILTER)	Take photos with filter effects.	66

The Focus Stick (Focus Lever)

Tilt or press the focus stick to select the focus area. The focus stick can also be used to navigate the menus.

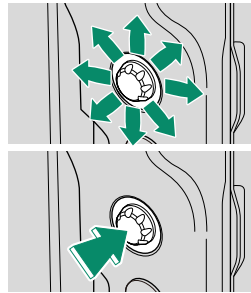







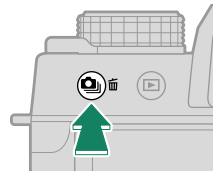



Use  **FUNCTION/DIAL SETTING > FOCUS LEVER SETTING** to choose the role played by the focus stick (📖 168).

(drive) button

Pressing the  (drive) button displays drive mode options, where you can choose from the following the drive modes.



Mode		Mode	
 STILL IMAGE	52	 FILM SIMULATION BKT	90
 CONTINUOUS	92	 WHITE BALANCE BKT	90
 AE BKT	90	 DYNAMIC RANGE BKT	91
 ISO BKT	90	 HDR	91

The Command Dials

The rear and front command dials are used for the operations below.

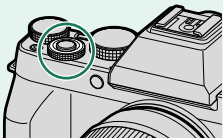
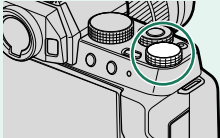

	Front command dial	Rear command dial
		
Shooting	<ul style="list-style-type: none">• Choose the desired combination of shutter speed and aperture (program shift).• Adjust aperture.• Choose a shutter speed.	<ul style="list-style-type: none">• Choose a shutter speed.• Adjust exposure compensation.
Menus	Select menu tabs or page through menus.	Highlight menu items.
Q Menu	Adjust settings in the quick menu.	
Playback	View other pictures.	<ul style="list-style-type: none">• Zoom in or out (full-frame playback).• Zoom in or out (multi-frame playback).

Fn (function) dial

Rotate the function dial to quickly adjust settings for the assigned function during shooting.

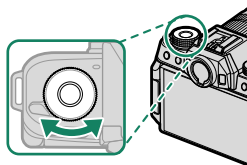

At shipment, the dial is assigned the **DEFAULT** role. At this setting, the function performed by the dial varies with the position of the mode dial.

Mode	Description
Adv. (ADVANCED FILTER)	Filter selection
SP (SCENE POSITION)	Scene selection
SR ⁺ (ADVANCED SR AUTO) / ▲ / 🏃 / 🌙	Self-timer
P (PROGRAM AE) S (SHUTTER PRIORITY AE) A (APERTURE PRIORITY AE) M (MANUAL) 📷 (PANORAMA)	Film simulation
🎥 (MOVIE)	Shutter speed

 The role performed by the function dial can be chosen using **🔍 BUTTON/DIAL SETTING > FUNCTION (Fn) SETTING** (📖 188).

The Indicator Lamp

The indicator lamp shows camera status as follows:

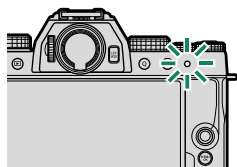

Indicator lamp	Camera status
Glows green	Focus locked.
Blinks green	Focus or slow shutter speed warning. Pictures can be taken.
Blinks green and orange	<ul style="list-style-type: none">• Camera on: Recording pictures. Additional pictures can be taken.• Camera off: Uploading pictures to a smartphone or tablet (Displayed only if pictures are selected for upload.)
Glows orange	Recording pictures. No additional pictures can be taken at this time.
Blinks orange	Flash charging; flash will not fire when picture is taken.
Blinks red	Lens or memory error.

 Warnings may also appear in the display.

The LCD Monitor

The LCD monitor can be tilted or reversed for ease of viewing. You will find this feature particularly helpful when shooting self-portraits (📖 96). Be careful not to catch your fingers or other objects between the monitor and the camera body.

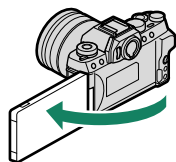

 The LCD monitor also functions as a touch screen (📖 19).

Focusing the Viewfinder

If the indicators displayed in the viewfinder are blurred, put your eye to the viewfinder and rotate the diopter adjustment control until the display is in sharp focus.

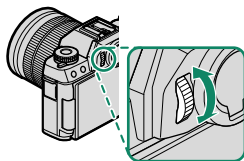

Camera Displays

During shooting, the viewfinder (EVF) and LCD monitor can function either as standard or touch menu displays.

! For illustrative purposes, displays are shown with all indicators lit.

The Standard Shooting Display

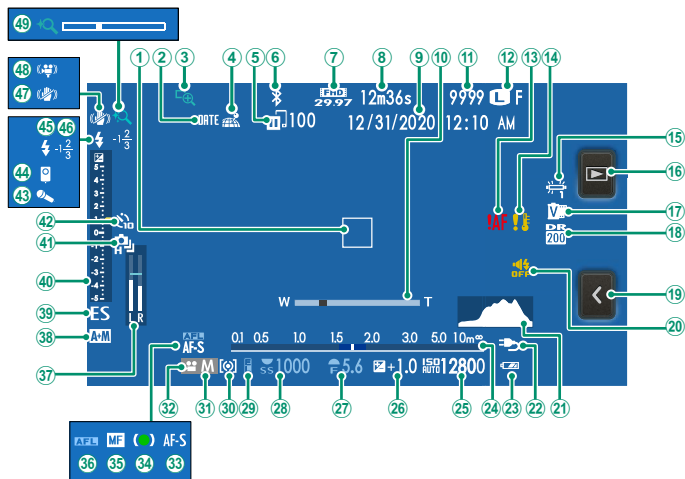

Icons that are displayed in both the electronic viewfinder (EVF) and LCD monitor have the same meaning in both displays.

① Focus frame.....	73, 80	②5 Sensitivity.....	118
② Date stamp.....	173	②6 Exposure compensation.....	79
③ Focus check.....	78, 109	②7 Aperture.....	53, 56, 57
④ Location data download status.....	177	②8 Shutter speed.....	53, 54, 57
⑤ Image transfer status.....	147	②9 AE lock.....	80
⑥ Bluetooth ON/OFF.....	174	③0 Metering.....	116
⑦ Movie mode.....	46, 124	③1 Shooting mode.....	4, 52
⑧ Time remaining.....	46	③2 Movie mode.....	4, 46
⑨ Date and time.....	36, 157	③3 Focus mode ⁵	69
⑩ Power zoom indicator.....	41	③4 Focus indicator ⁵	70
⑪ Number of available frames ¹	243	③5 Manual focus indicator ⁵	77
⑫ Image size.....	98	③6 AF lock.....	80
Image quality.....	99	③7 Recording level.....	129
⑬ Focus warning.....	41	③8 AF+MF indicator ⁵	108
⑭ Temperature warning.....	242	③9 Shutter type.....	117
⑮ White balance.....	81	④0 Exposure indicator.....	57, 79
⑯ Playback mode button ²	42	④1 Continuous mode.....	92
⑰ Film simulation.....	100	④2 Self-timer indicator.....	85
⑱ Dynamic range.....	102	④3 Microphone.....	46
⑲ Touch menu button ³	12	④4 Remote release.....	55, 59
⑳ Sound and flash indicator.....	158	④5 Flash mode.....	94
㉑ Histogram.....	17	④6 Flash compensation.....	94, 123
㉒ External power source in use.....	see below	④7 IS mode ⁵	118
㉓ Battery level.....	35	④8 Digital gimbal.....	125
㉔ Distance indicator ⁵	78	④9 Touch zoom ⁴	22

- Shows “9999” if there is space for over 9999 frames.
- Tap to start playback when shooting in self-portrait (“selfie”) mode.
- Tap to switch to the touch menu display (☰ 12).
- Adjust digital zoom settings.
- Not displayed when **ON** is selected for **SCREEN SET-UP > LARGE INDICATORS MODE (EVF)** or **LARGE INDICATORS MODE (LCD)**.

 The camera shows “External power source in use” in place of the battery level when a DC coupler is connected (☰ 112).

The Touch Menu Display

Select the touch menu display to use touch controls.

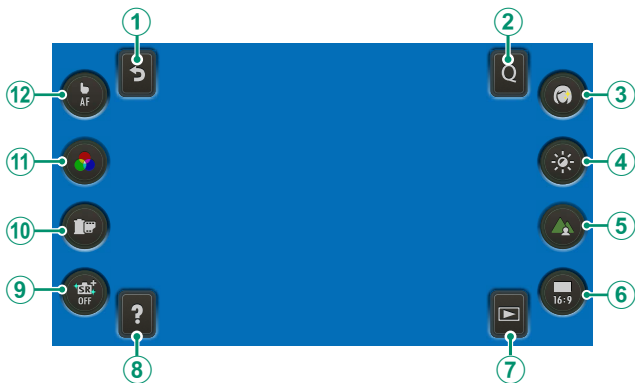





Touch control	Description
① Back	Return to standard shooting mode (📖 10).
② Q menu	View the options assigned to the Q menu (📖 183).
③ Portrait enhancer Lv	Choose the portrait enhancement level (📖 101).
④ Exposure compensation	Adjust exposure (📖 79).
⑤ Depth control	Adjust depth of field.
⑥ Image aspect	Choose the aspect ratio for new pictures.
⑦ Playback mode	Switch to playback mode (📖 42).
⑧ Help	View function button help.
⑨ Bright mode	Turn bright mode on or off.
⑩ T.B. Fn2	View the options assigned to the function buttons using 📖 BUTTON/DIAL SETTING > FUNCTION (Fn) SETTING (📖 189).
⑪ T.B. Fn1	
⑫ Touch screen mode	Choose a touch-screen mode from TOUCH SHOOTING, AF, AREA, and OFF (📖 19).

- Tap the “image aspect” icon (⑥) to choose from aspect ratios of **16:9**, **1:1**, **4:3**, and **3:2**.
- Icons that are displayed in both the electronic viewfinder (EVF) and LCD monitor have the same meaning in both displays.
- The touch menu can also be navigated using the focus stick (focus lever).

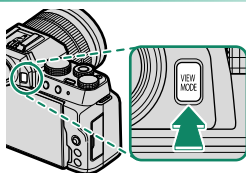
Choosing a Display Mode

Press the **VIEW MODE** button to cycle through the following display modes.



Option	Description
 EYE SENSOR	Putting your eye to the viewfinder turns the viewfinder on and the LCD monitor off; taking your eye away turns the viewfinder off and LCD monitor on.
EVF ONLY	Viewfinder on, LCD monitor off.
LCD ONLY	LCD monitor on, viewfinder off.
EVF ONLY + 	Putting your eye to the viewfinder turns the viewfinder on; taking it away turns the viewfinder off. The LCD monitor remains off.
 EYE SENSOR + LCD IMAGE DISP.	Putting your eye to the viewfinder during shooting turns the viewfinder on, but the LCD monitor is used for the display of images once you remove your eye from the viewfinder after shooting.

The Eye Sensor

- The eye sensor may respond to objects other than your eye or to light shining directly on the sensor.
- The eye sensor is disabled when the display in the monitor is reversed (📖 96).

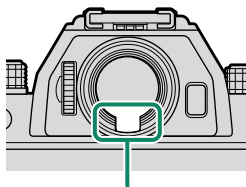

Eye sensor

Adjusting Display Brightness

The brightness and hue of the viewfinder and LCD monitor can be adjusted using the items in the **SCREEN SET-UP** menu. Choose **EVF BRIGHTNESS** or **EVF COLOR** to adjust viewfinder brightness or hue, **LCD BRIGHTNESS** or **LCD COLOR** to do the same for the LCD monitor.

 Holding the **DISP/BACK** button during shooting sets **LCD BRIGHTNESS** to **+5** and displays **LCD BRIGHTNESS** options.

Display Rotation

When **ON** is selected for **SCREEN SET-UP > AUTOROTATE DISPLAYS**, the indicators in the viewfinder and LCD monitor automatically rotate to match camera orientation.

The DISP/BACK Button

Press **DISP/BACK** to cycle through display modes as follows.

 Indicators for the EVF and LCD must be selected separately. To choose the EVF display, place your eye to the viewfinder while using the **DISP/BACK** button.

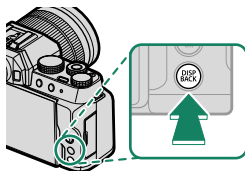

Viewfinder

Standard



Information off



LCD Monitor

Standard



Information off



Info display



Customizing the Standard Display

To choose the items shown in the standard display:

1 Display standard indicators.

Use the **DISP/BACK** button to display standard indicators.

2 Select **DISP. CUSTOM SETTING**.

Select **SCREEN SET-UP > DISP. CUSTOM SETTING** in the setup menu.

3 Choose items.

Highlight items and press **MENU/OK** to select or deselect.

Item	Default	Item	Default
FRAMING GUIDELINE	<input type="checkbox"/>	SHUTTER TYPE	<input checked="" type="checkbox"/>
ELECTRONIC LEVEL	<input type="checkbox"/>	FLASH	<input checked="" type="checkbox"/>
FOCUS FRAME	<input checked="" type="checkbox"/>	CONTINUOUS MODE	<input checked="" type="checkbox"/>
AF DISTANCE INDICATOR	<input type="checkbox"/>	DUAL IS MODE	<input checked="" type="checkbox"/>
MF DISTANCE INDICATOR	<input checked="" type="checkbox"/>	WHITE BALANCE	<input type="checkbox"/>
HISTOGRAM	<input type="checkbox"/>	FILM SIMULATION	<input type="checkbox"/>
SHOOTING MODE	<input checked="" type="checkbox"/>	DYNAMIC RANGE	<input checked="" type="checkbox"/>
APERTURE/S-SPEED/ISO	<input checked="" type="checkbox"/>	FRAMES REMAINING	<input checked="" type="checkbox"/>
INFORMATION BACKGROUND	<input type="checkbox"/>	IMAGE SIZE/QUALITY	<input type="checkbox"/>
Expo. Comp. (Digit)	<input type="checkbox"/>	MOVIE MODE & REC. TIME	<input checked="" type="checkbox"/>
Expo. Comp. (Scale)	<input checked="" type="checkbox"/>	IMAGE TRANSFER ORDER	<input checked="" type="checkbox"/>
FOCUS MODE	<input type="checkbox"/>	MIC LEVEL	<input checked="" type="checkbox"/>
PHOTOMETRY	<input type="checkbox"/>	BATTERY LEVEL	<input type="checkbox"/>

4 Save changes.

Press **DISP/BACK** to save changes.

5 Exit the menus.

Press **DISP/BACK** as needed to exit the menus and return to the shooting display.

Virtual Horizon

Selecting **ELECTRONIC LEVEL** displays a virtual horizon. The camera is level when the two lines overlap. Note that the virtual horizon may not be displayed if the camera lens is pointed up or down.

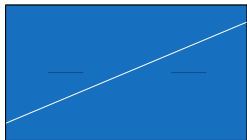

Histograms

Histograms show the distribution of tones in the image. Brightness is shown by the horizontal axis, the number of pixels by the vertical axis.

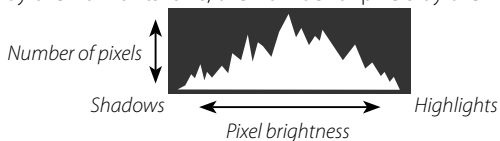

- **Optimal exposure:** Pixels are distributed in an even curve throughout the tone range.
- **Overexposed:** Pixels are clustered on the right side of the graph.
- **Underexposed:** Pixels are clustered on the left side of the graph.

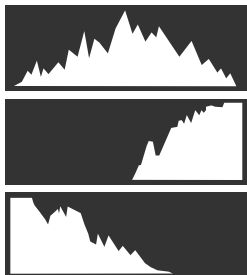

Using the Menus

To display the menus, press **MENU/OK**.

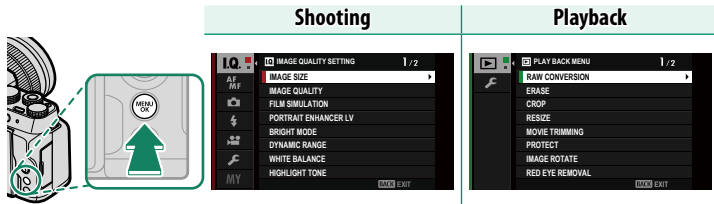

To navigate the menus:

- 1 Press **MENU/OK** to display the menus.

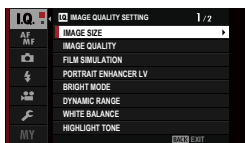

- 2 Press the focus stick (focus lever) left to highlight the tab for the current menu.

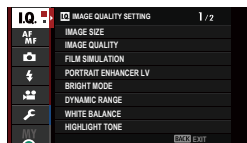

Tab

- 3 Press the focus stick up or down to highlight the tab (**I.Q.**, **AF/M.F.**, **📷**, **⚡**, **👤**, **MY**, **📺** or **📷**) containing the desired item.
- 4 Press the focus stick right to place the cursor in the menu.



- You can also navigate the menu using touch controls.
- Use the front command dial to select menu tabs or page through menus and the rear command dial to highlight menu items.

Touch Screen Mode

The camera's LCD monitor can be used as a touch screen.

Shooting Touch Controls

To enable touch controls, select **ON** for **▶️ BUTTON/DIAL SETTING > TOUCH SCREEN SETTING > 📷 TOUCH SCREEN SETTING**.

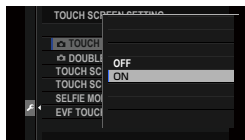

EVF

The LCD monitor can be used to select the focus area while pictures are being framed in the electronic viewfinder (EVF). Use **▶️ BUTTON/DIAL SETTING > TOUCH SCREEN SETTING > EVF TOUCH SCREEN AREA SETTINGS** to choose the area of the monitor employed for touch controls.

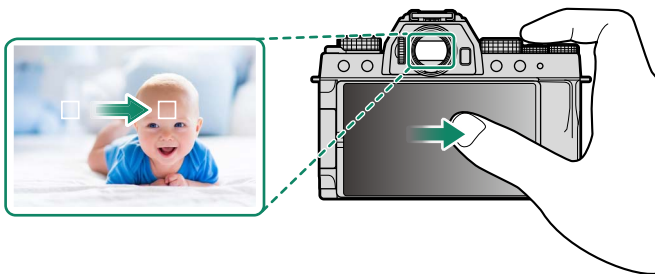

LCD Monitor

Use touch controls to take photographs or adjust camera settings.

The Touch Menu

Shooting settings can be adjusted in the touch menu, which can be viewed by tapping the touch menu button.

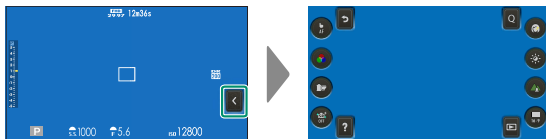





Touch Photography

Touch controls can be used for such operations as choosing the focus area and taking photographs. Tap the touch screen mode icon to choose a touch screen mode.















- To disable touch controls and hide the touch screen mode indicator, select **OFF** for **FUNCTION/DIAL SETTING > TOUCH SCREEN SETTING > TOUCH SCREEN SETTING**.
- When **ON** is selected for **FUNCTION/DIAL SETTING > TOUCH SCREEN SETTING > DOUBLE TAP SETTING**, you can zoom in on the shooting display by tapping the monitor twice.
- Touch control settings can be adjusted using **AF/MF SETTING > TOUCH SCREEN MODE**.

• Still Photography

Mode	Description
 TOUCH SHOOTING	Tap your subject in the display to focus and release the shutter. In burst mode, pictures will be taken while you keep your finger on the display.
 AF	Tap to select a focus point and lock focus. The shutter can be released by pressing the shutter button all the way down.
 AREA	Tap to select a point for focus or zoom. The focus frame will move to the selected point.
 OFF	Touch controls off.

• Movie Recording

Mode	Description
 AF	<ul style="list-style-type: none"> • SINGLE AF selected for  MOVIE SETTING >  FOCUS MODE: Tap your subject in the display to focus. • CONTINUOUS AF selected for  MOVIE SETTING >  FOCUS MODE: The camera continually adjusts focus in response to changes in the distance to the subject in the selected focus point.
 AREA	<ul style="list-style-type: none"> • SINGLE AF selected for  MOVIE SETTING >  FOCUS MODE: Tap to select the focus point. The camera will focus on the subject in the selected point when the shutter button is pressed halfway. • CONTINUOUS AF selected for  MOVIE SETTING >  FOCUS MODE: The camera continually adjusts focus in response to changes in the distance to the subject in the selected focus point.
 OFF	Touch controls off.

 We recommend that you select **AREA** for  **MOVIE SETTING** > **MOVIE AF MODE** before recording movies using touch controls. In some touch-screen modes, **AREA** will be selected automatically.

Touch Zoom

Touch controls can be used for digital zoom.

 Touch controls can be used for digital zoom regardless of the mode selected for **AF/MF SETTING > TOUCH SCREEN MODE**.

- 1 Select **ON** for **SHOOTING SETTING > TOUCH ZOOM**.
- 2 Use pinch-out and pinch-in gestures (📖 23) to zoom in and out using digital zoom.



-  Regardless of where you place your fingers, the camera will zoom in on and out from the center of the frame.
- The camera will focus on the area selected for **AF/MF SETTING > FOCUS AREA**. If **AREA** is selected for **AF/MF SETTING > TOUCH SCREEN MODE**, you can select the focus area by tapping the display.

- 3 Take pictures.

Playback Touch Controls

When **ON** is selected for **▶️ BUTTON/DIAL SETTING > TOUCH SCREEN SETTING > ▶️ TOUCH SCREEN SETTING**, touch controls can be used for the following playback operations:

- **Swipe:** Swipe a finger across the display to view other images.



- **Pinch-out:** Place two fingers on the display and spread them apart to zoom in.



- **Pinch-in:** Place two fingers on the display and slide them together to zoom out.



 Pictures can be zoomed out until the entire image is visible but no further.

- **Double-tap:** Tap the display twice to zoom in on the focus point.



- **Drag:** View other areas of the image during playback zoom.



First Steps

2

Attaching the Shoulder Strap

Attach the strap to the two strap eyelets as shown below.

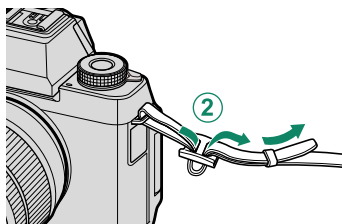
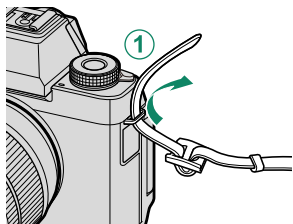

- ! • Attach the strap as shown.
- To avoid dropping the camera, be sure the strap is correctly secured.

Attaching a Lens

The camera can be used with lenses for the FUJIFILM X-mount.

Remove the body cap from the camera and the rear cap from the lens. Place the lens on mount, keeping the marks on the lens and camera aligned (①), and then rotate the lens until it clicks into place (②).

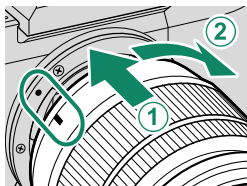

- ⚠ When attaching lenses, ensure that dust or other foreign matter does not enter the camera.
- Be careful not to touch the camera's internal parts.
- Rotate the lens until it clicks securely into place.
- Do not press the lens release button while attaching the lens.

Removing Lenses

To remove the lens, turn the camera off, then press the lens release button (①) and rotate the lens as shown (②).

- ⚠ To prevent dust accumulating on the lens or inside the camera, replace the lens caps and camera body cap when the lens is not attached.

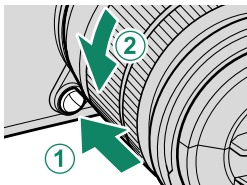

Lenses and Other Optional Accessories

The camera can be used with lenses and accessories for the FUJIFILM X-mount.

- ⚠ Observe the following precautions when attaching or removing (exchanging) lenses.
- Check that the lenses are free of dust and other foreign matter.
- Do not change lenses in direct sunlight or under another bright light source. Light focused into the interior of the camera could cause it to malfunction.
- Attach the lens caps before exchanging lenses.

Inserting the Battery and a Memory Card

Insert the battery and memory card as described below.

1 Open the battery-chamber cover.

Slide the battery-chamber latch as shown and open the battery-chamber cover.

- Do not remove the battery when the camera is on. Failure to observe this precaution could damage image files or memory cards.
- Do not use excessive force when handling the battery-chamber cover.

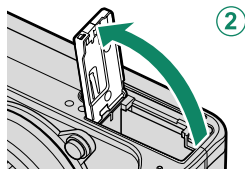
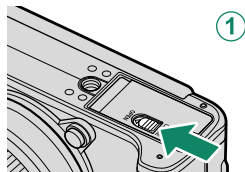

2 Insert the battery.

Using the battery to keep the battery latch pressed to one side, insert the battery contacts first in the direction shown by the arrow.

- Insert the battery in the orientation shown. *Do not use force or attempt to insert the battery upside down or backwards.* The battery will slide in easily in the correct orientation.
- Confirm that the battery is securely latched.

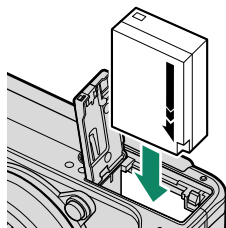

3 Insert the memory card.

Holding the card in the orientation shown, slide it in until it clicks into place at the back of the slot.

- ❗ Be sure card is in the correct orientation; do not insert at an angle or use force.
- Format memory cards before first use, and be sure to reformat all memory cards after using them in a computer or other device.

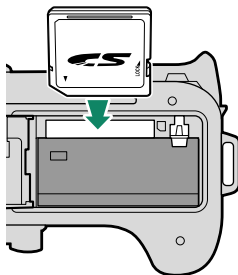

4 Close the battery-chamber cover.

Close and latch the cover.

- ❗ If the cover does not close, check that the battery is in the correct orientation. Do not attempt to force the cover shut.

Removing the Battery

Before removing the battery or memory card, *turn the camera off* and open the battery-chamber cover.

To remove the battery, press the battery latch to the side, and slide the battery out of the camera as shown.

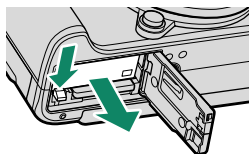

⚠ The battery may become hot when used in high-temperature environments. Observe caution when removing the battery.

Removing Memory Cards

To remove the memory card, press it in and release it slowly. The card can then be removed by hand.

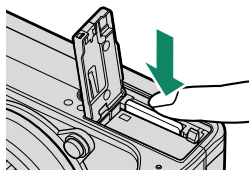



⚠

- Press the center of the card when ejecting it.
- When a memory card is removed, the card could be ejected too quickly. Use your finger to hold it and gently release the card.

Compatible Memory Cards

- The camera can be used with SD, SDHC, and SDXC memory cards.
- The camera supports UHS-I memory cards.
- Use a memory card with a UHS speed class of 3 or better when recording movies.
- A list of supported memory cards is available on the Fujifilm website. For details, visit: <https://fujifilm-x.com/support/compatibility/>.

-  • Do not turn the camera off or remove the memory card while the memory card is being formatted or data are being recorded to or deleted from the card. Failure to observe this precaution could damage the card.
- Memory cards can be locked, making it impossible to format the card or to record or delete images. Before inserting a memory card, slide the write-protect switch to the unlocked position. 
 - Memory cards are small and can be swallowed; keep out of reach of children. If a child swallows a memory card, seek medical assistance immediately.
 - miniSD or microSD adapters that are larger or smaller than memory cards may not eject normally; if the card does not eject, take the camera to an authorized service representative. Do not forcibly remove the card.
 - Do not affix labels or other objects to memory cards. Peeling labels can cause camera malfunction.
 - Movie recording may be interrupted with some types of memory card.
 - Formatting a memory card in the camera creates a folder in which pictures are stored. Do not rename or delete this folder or use a computer or other device to edit, delete, or rename image files. Always use the camera to delete pictures; before editing or renaming files, copy them to a computer and edit or rename the copies, not the originals. Renaming the files on the camera can cause problems during playback.

Charging the Battery

The battery is not charged at shipment. Charge the battery before use.

- An NP-W126S rechargeable battery is supplied with the camera.
- Turn the camera off before charging the battery.

- The camera can be charged via USB. USB charging is available with computers with a manufacturer-approved operating system and USB interface.

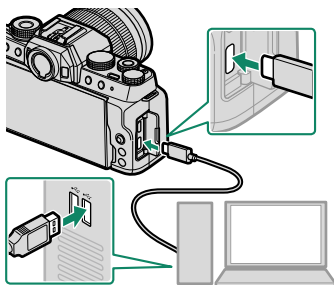

Leave the computer on during charging.

- The battery will not charge while the camera is on.
- Use the supplied USB cable.
- Connect the camera directly to the computer; do not use a USB hub or keyboard.
- Charging stops if the computer enters sleep mode; to resume charging, activate the computer and disconnect and reconnect the USB cable.
- Charging may not be supported depending on the model of computer, computer settings, and the computer's current state.
- With an input of 5 V/500 mA, charging time is about 6 hours 30 minutes.

- To charge the battery from a household AC power outlet, use a BC-W126S battery charger (available separately).

Charge Status

The indicator lamp shows battery charge status as follows:

Indicator lamp	Battery status
On	Battery charging.
Off	Charging complete.
Blinks	Battery fault.

-  Do not affix labels or other objects to the battery. Failure to observe this precaution could make it impossible to remove the battery from the camera.
- Do not short the battery terminals. The battery could overheat.
- Read the cautions in “The Battery and Power Supply”.
- Use only genuine Fujifilm rechargeable batteries designated for use in this camera. Failure to observe this precaution could result in product malfunction.
- Do not remove the labels from the battery or attempt to split or peel the outer casing.
- The battery gradually loses its charge when not in use. Charge the battery one or two days before use.
- If the battery fails to hold a charge, it has reached the end of its charging life and must be replaced.
- Remove dirt from the battery terminals with a clean, dry cloth. Failure to observe this precaution could prevent the battery from charging.
- Note that charging times increase at low or high temperatures.

Turning the Camera On and Off

Use the **ON/OFF** button to turn the camera on and off.

Press the **ON/OFF** button once to turn the camera on and again to turn it off.

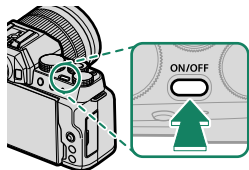

! Fingerprints and other marks on the lens or viewfinder can affect pictures or the view through the viewfinder. Keep the lens and viewfinder clean.





- ◆**
- Pressing the **▶** button during shooting starts playback.
 - Press the shutter button halfway to return to shooting mode.
 - The camera will turn off automatically if no operations are performed for the length of time selected for **▶ POWER MANAGEMENT > AUTO POWER OFF**. To reactivate the camera and return to shooting mode after the camera has turned off automatically, press the shutter button halfway or press the **ON/OFF** button.

Checking the Battery Level

After turning the camera on, check the battery level in the display.

Battery level is shown as follows:



Indicator	Description
 (white)	Battery partially discharged.
 (white)	Battery about two-thirds charged.
 (white)	Battery about one-third charged. Charge as soon as possible.
 (red)	Low battery. Charge battery.
 (blinks red)	Battery exhausted. Turn camera off and recharge battery.

Basic Setup

When you turn the camera on for the first time, you can choose a language and set the camera clock. At default settings, you can also pair the camera with a smartphone or tablet so that you can later synchronize the clocks or download pictures. Follow the steps below when turning the camera on for the first time.

 If you intend to pair the camera with a smartphone or tablet, install and launch the latest version of the FUJIFILM Camera Remote App on the smart device before proceeding. For more information, visit: http://app.fujifilm-dsc.com/en/camera_remote/

1 Turn the camera on.

A language-selection dialog will be displayed.

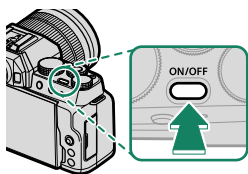

2 Choose a language.

Highlight a language and press **MENU/OK**.

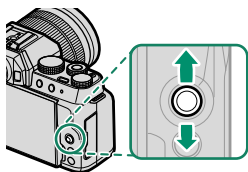

3 Pair the camera with the smartphone or tablet.

Press the **MENU/OK** button to pair the camera with a smartphone to which the FUJIFILM Camera Remote app has been installed.



 To skip pairing, press **DISP/BACK**.

4 Check the time.

When pairing is complete, you will be prompted to set the camera clock to the time reported by the smartphone or tablet. Check that the time is correct.



 To set the clock manually, press **DISP/BACK** (📖 38).

5 Synchronize the camera settings with the settings configured on your smartphone or tablet.

 The option selected can be changed at any time using **CONNECTION SETTING > Bluetooth SETTINGS**.

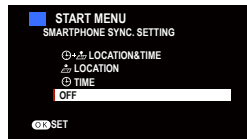

6 Set the clock.

Press **MENU/OK** to set the camera clock to the time reported by the smartphone or tablet and exit to shooting mode.

7 Format the memory card (📖 156).

 Format memory cards before first use, and be sure to reformat all memory cards after using them in a computer or other device.



 If the battery is removed for an extended period, the camera clock will be reset and the language-selection dialog will be displayed when the camera is turned on.

Skipping the Current Step

If you skip a step, a confirmation dialog will be displayed; select **NO** to avoid repeating any steps you skipped the next time the camera is turned on.

Choosing a Different Language

To change the language:

- 1 Display language options.**
Select  **USER SETTING** >  **言語/LANG..**
- 2 Choose a language.**
Highlight the desired option and press **MENU/OK**.

Changing the Time and Date

To set the camera clock:

- 1 Display DATE/TIME options.**
Select  **USER SETTING** > **DATE/TIME**.
- 2 Set the clock.**
Press the focus stick (focus lever) left or right to highlight the year, month, day, hour, or minute and press up or down to change. Press **MENU/OK** to set the clock.

Basic Photography and Playback

3

Taking Photographs

This section explains basic photography.

1 Select **SR+** mode.

Rotate the mode dial to **SR+** (ADVANCED SR AUTO). The following information will be displayed in the LCD monitor.

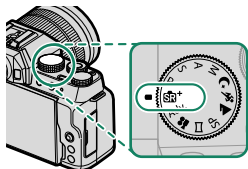

The camera automatically selects a scene according to the type of subject detected.

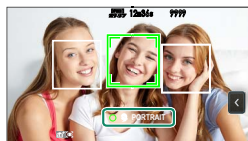

! In **SR+** mode, the camera continuously adjusts focus and searches for eyes, increasing the drain on the battery; in addition, the sound of the camera focusing may be audible.

2 Ready the camera.

Hold the camera steady with both hands—shaking or unsteady hands can blur your shots.

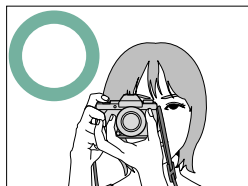

To prevent pictures that are out of focus or too dark (underexposed), keep your fingers and other objects away from the lens, flash, and AF-assist illuminator.

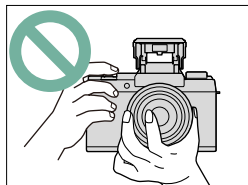

3 Frame the picture.

Lenses with Zoom Rings

Use the zoom ring to frame the picture in the display. Rotate the ring left to zoom out, right to zoom in.

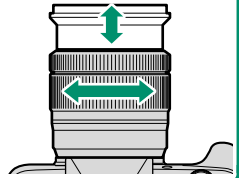

4 Focus.

Press the shutter button halfway to focus.

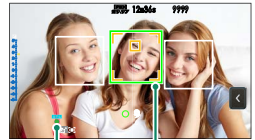

Focus indicator

Focus frame

- **If the camera is able to focus**, it will beep twice, the focus frame will turn amber and green, and the focus indicator will turn green.
- **If the camera is unable to focus**, the focus frame will turn red, **!AF** will be displayed, and the focus indicator will blink white.



- If the subject is poorly lit, the AF-assist illuminator may light to assist the focus operation.
- Focus and exposure will lock when the shutter button is pressed halfway. Focus and exposure remain locked while the button is kept in this position (AF/AE lock).
- The camera will focus on subjects at any distance in the macro and standard focus ranges for the lens.

5 Shoot.

Smoothly press the shutter button the rest of the way down to take the picture.



Viewing Pictures

Pictures can be viewed in the LCD monitor.

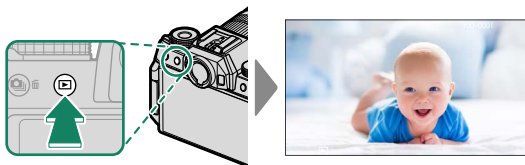
To view pictures full frame, press .



Press the focus stick (focus lever) left to page through pictures in reverse order. Press it right to page through pictures in the order recorded. Keep the stick pressed to scroll rapidly to the desired frame.

-  You can also page through pictures using the front command dial or swipe gestures.
- Pictures taken using other cameras are marked with a  ("gift image") icon to warn that they may not display correctly and that playback zoom may not be available.



Deleting Pictures

Use the  (delete) button to delete pictures.



Deleted pictures cannot be recovered. Copy important pictures to a computer or other storage device before proceeding.

- 1 With a picture displayed full frame, press the  button and select **FRAME**.

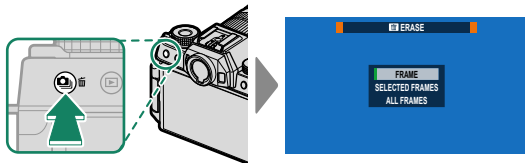

- 2 Choose a picture and press **MENU/OK** to delete it.
 - The picture will be deleted when the **MENU/OK** button is pressed; a confirmation dialog is not displayed. Be careful not to accidentally delete pictures you wish to keep.
 - Additional pictures can be deleted using the **MENU/OK** button. Display the desired pictures and press **MENU/OK** to delete them one by one.



- Protected pictures cannot be deleted. Remove protection from any pictures you wish to delete (📖 144).
- Pictures can also be deleted from the menus using the  **PLAY BACK MENU > ERASE** option (📖 139).

Movie Recording and Playback

4



Recording Movies

Record movies with sound.

- 1 Press to start recording.

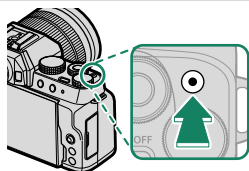

- A recording indicator () is displayed while recording is in progress.
- The time remaining is displayed while recording is in progress.

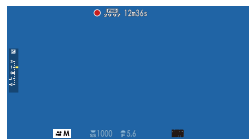

- 2 Press again to end recording.

Recording ends automatically when the maximum length is reached or the memory card is full.



When the mode dial is rotated to (MOVIE), the shutter button can be used for movie recording.

Using an External Microphone



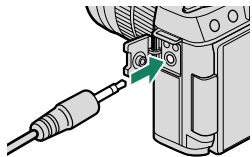



Sound can be recorded with external microphones that connect using jacks 3.5 mm in diameter; microphones that require plug-in power cannot be used. See the microphone manual for details.



- ❗ • Use a memory card with a UHS speed class of 3 or better when recording movies.
- Touch digital zoom ends when recording begins.
- The crop used for movies shot with **ON** selected for **MOVIE SETTING > DIGITAL IMAGE STABILIZER** or **DIGITAL GIMBAL** differs from the standard crop.
- Sound is recorded via the built-in microphone or an optional external microphone. Do not cover the microphone during recording.
- Note that the microphone may pick up lens noise and other sounds made by the camera during recording.
- Vertical or horizontal streaks may appear in movies containing very bright subjects. This is normal and does not indicate a malfunction.

- 📄 • The indicator lamp lights while recording is in progress.
- In the case of zoom lenses, zoom can be adjusted during recording using the zoom ring (if available).
- Exposure compensation can be adjusted during recording, but only by a maximum of ± 2 EV.
- Recording may be unavailable at some settings, while in other cases settings may not apply during recording.
- Headphones connected via USB can be used to monitor audio during movie recording. Use the supplied headphone adapter to convert the USB connector to a plug for a headphone jack.

Adjusting Movie Settings

- Adjust movie settings in the  **MOVIE SETTING** menu.
- Selecting an option other than **OFF** for  **MOVIE SETTING** > **HDR MOVIE MODE** or **FULL HD HIGH SPEED REC** overrides the option selected for **MOVIE MODE**; in the former case, movies will be shot using HDR, while in the latter they will be recorded at high speed in Full HD.
- The movie type, frame size, and frame rate can be selected using  **MOVIE SETTING** > **MOVIE MODE**.
- The AF-area mode for movie recording is selected using  **MOVIE SETTING** > **MOVIE AF MODE**; choose from **MULTI** and **AREA**.
- Focus mode is selected using  **MOVIE SETTING** >  **FOCUS MODE**; for continuous focus adjustment, select **CONTINUOUS AF** or choose **SINGLE AF** and enable Intelligent Face Detection. Intelligent Face Detection is not available in manual focus mode.

Depth of Field

To soften backgrounds, set aperture as wide as possible. Aperture can be adjusted directly in modes **A** (aperture-priority AE) and **M** (manual). In modes **P** (program AE), **A** (aperture-priority AE), and **M** (manual), aperture can be adjusted using the touch menu depth control. Adjust aperture before recording begins.

Viewing Movies

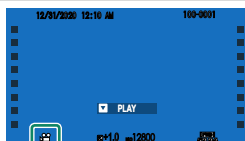

View movies on the camera.

In full-frame playback, movies are identified by a  icon. Press the focus stick (focus lever) down to start movie playback.



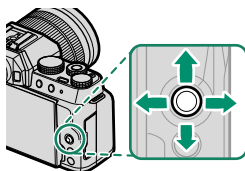

The following operations can be performed while a movie is displayed:



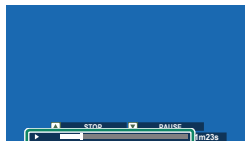

Focus stick (focus lever)	Full-frame playback	Playback in progress 	Playback paused 
Up	—	End playback	
Down	Start playback	Pause playback	Start/resume playback
Left/right	View other pictures	Adjust speed	Single frame rewind/advance

Progress is shown in the display during playback.



 Do not cover the speaker during playback.
 • Sound is not played back if **OFF** is selected for  **USER SETTING** > **SOUND & FLASH**.

 Press **MENU/OK** to pause playback and display volume controls. Press the focus stick (focus lever) up or down to adjust the volume; press **MENU/OK** again to resume playback. Volume can also be adjusted using  **SOUND SET-UP** > **PLAYBACK VOLUME**.
 • Audio can be played back over headphones or other devices connected via USB using the supplied headphone adapter.

Playback Speed

Press the focus stick (focus lever) left or right to adjust playback speed during playback. Speed is shown by the number of arrows (▶ or ◀).

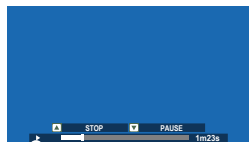

Arrows

Taking Photographs

5

Choosing a Shooting Mode

Choose a shooting mode according to the scene or type of subject.

SR⁺ ADVANCED SR AUTO

When the mode dial is rotated to SR⁺, the camera automatically optimizes settings to suit the scene.

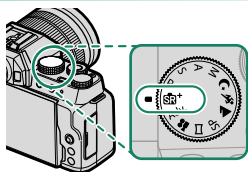

The camera automatically selects a scene according to the type of subject detected.

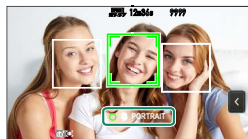

Scene
AUTO
PORTRAIT
LANDSCAPE
NIGHT

Scene
MACRO
NIGHT PORTRAIT
BACKLIT PORTRAIT

! The mode selected may vary with shooting conditions. If the mode and subject do not match, select mode **P** or choose **SP** and select a scene manually.

Program AE (P)

Let the camera choose shutter speed and aperture for optimal exposure. Other values that produce the same exposure can be selected with program shift.

Rotate the mode dial to P.

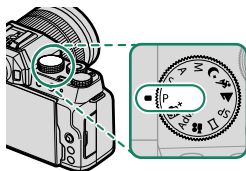

P will appear in the display.



Program Shift

Rotate the front command dial to choose the desired combination of shutter speed and aperture (program shift).



Shutter speed
Aperture

- ⚠ Program shift is not available in any of the following circumstances:
- With flash units that support TTL auto
 - When an option other than **Ⓢ SUPPRESSED FLASH** is selected for **⚡ FLASH SETTING**
 - When an auto option is selected for **📷 IMAGE QUALITY SETTING > DYNAMIC RANGE**

🔌 To cancel program shift, turn the camera off.

Shutter-Priority AE (S)

Choose a shutter speed and let the camera adjust aperture for optimal exposure.

- 1 Rotate the mode dial to S.

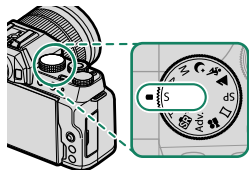

S will appear in the display.



- 2 Use the front command dial to choose a shutter speed.

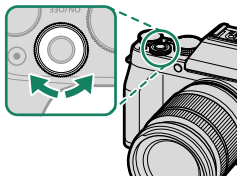

! If the correct exposure cannot be achieved at the selected shutter speed, aperture will be displayed in red.

Time (T)

Shutter speeds of 1 s or slower are referred to as “long time-exposures”. Use of a tripod is recommended to prevent the camera moving during the exposure.

- A count-down timer will be displayed while the exposure is in progress.
- To reduce “noise” (mottling) in long time-exposures, select **ON** for **IMAGE QUALITY SETTING > LONG EXPOSURE NR.** Note that this may increase the time needed to record images after shooting.

Using a Remote Release

A remote release can be used for long time-exposures. When using an optional RR-100 remote release or an electronic release from third-party suppliers, connect it to the camera’s remote release connector.

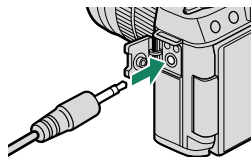

- ! Use a third-party ø2.5 mm to 3.5 mm adapter when connecting an optional RR-100 remote release.

- A confirmation dialog will be displayed when a remote release is connected; press **MENU/OK** and select **REMOTE** for **MIC/REMOTE RELEASE**.

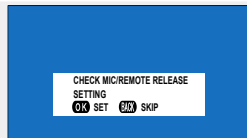

Aperture-Priority AE (A)

Choose an aperture and let the camera adjust shutter speed for optimal exposure.

- 1 Rotate the mode dial to A.

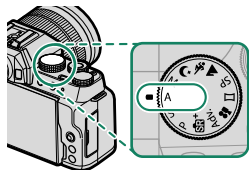

A will appear in the display.



- 2 Use the front command dial to choose an aperture.

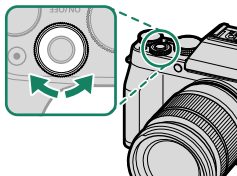

! If the correct exposure cannot be achieved at the selected aperture, shutter speed will be displayed in red.

Manual Exposure (M)

Alter exposure from that selected by the camera.

- 1 Rotate the mode dial to M.

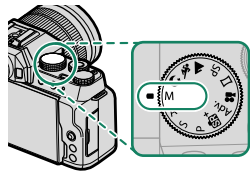

M will appear in the display.



- 2 Rotate the rear command dial to choose a shutter speed and the front command dial to choose the aperture.

 The manual exposure display includes an exposure indicator that shows the amount the picture would be under- or over-exposed at current settings.

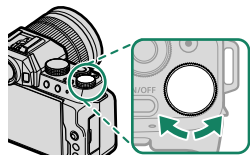

Shutter speed

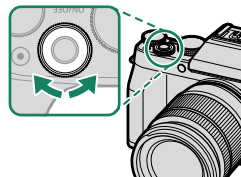

Aperture

Exposure Preview

To preview exposure in the LCD monitor, select an option other than **OFF** for **SCREEN SET-UP > PREVIEW EXP./WB IN MANUAL MODE**.



Select **OFF** when using the flash or on other occasions on which exposure may change when the picture is taken.

Bulb (B)

For bulb photography, rotate the rear command dial to select a shutter speed of **BULB**. Use of a tripod is recommended to prevent the camera moving during the exposure.

- The shutter will remain open for up to 60 minutes, or for 1 second when the electronic shutter is used.
- A count-down timer will be displayed while the exposure is in progress.
- To reduce “noise” (mottling) in long time-exposures, select **ON** for **IMAGE QUALITY SETTING > LONG EXPOSURE NR.** Note that this may increase the time needed to record images after shooting.

Using a Remote Release

A remote release can be used for long time-exposures. When using an optional RR-100 remote release or an electronic release from third-party suppliers, connect it to the camera’s remote release connector.

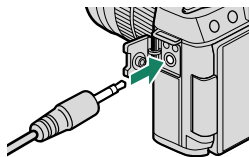

- ! Use a third-party $\varnothing 2.5$ mm to 3.5 mm adapter when connecting an optional RR-100 remote release.

- A confirmation dialog will be displayed when a remote release is connected; press **MENU/OK** and select **REMOTE** for **MIC/REMOTE RELEASE**.

CHECK MIC/REMOTE RELEASE
SETTING
OK SET **EXIT** SKIP

☐ PANORAMA

Follow an on-screen guide to create a panorama.

- 1 Rotate the mode dial to ☐ (PANORAMA).

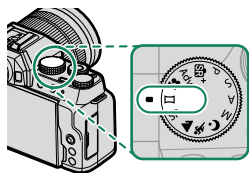

- 2 To select the size of the angle through which you will pan the camera while shooting, press the focus stick (focus lever) left. Highlight a size and press **MENU/OK**.
- 3 Press the focus stick right to view a choice of pan directions. Highlight a pan direction and press **MENU/OK**.
- 4 Press the shutter button all the way down to start recording. There is no need to keep the shutter button pressed during recording.

- 5 Pan the camera in the direction shown by the arrow. Shooting ends automatically when the camera is panned to the end of the guides and the panorama is complete.

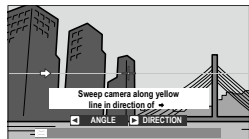

For Best Results

For best results, use a lens with a focal length of 35 mm or less (50mm or less in 35 mm format). Prop your elbows against your sides and move the camera slowly in a small circle at a steady speed, keeping the camera parallel or at right angles to the horizon and being careful only to pan in the direction shown by the guides. Use a tripod for best results. If the desired results are not achieved, try panning at a different speed.

- ❗ • If the shutter button is pressed all the way down before the panorama is complete, shooting will end and no panorama may be recorded.
- The last part of the panorama may not be recorded if shooting ends before the panorama is complete.
- Panoramas are created from multiple frames, and the camera may in some cases be unable to stitch the frames together perfectly.
- Panoramas may be blurred if the subject is poorly lit.
- Shooting may be interrupted if the camera is panned too quickly or too slowly. Panning the camera in a direction other than that shown cancels shooting.
- The camera may in some cases record a greater or lesser angle than selected.
- The desired results may not be achieved with:
 - Moving subjects
 - Subjects close to the camera
 - Unvarying subjects such as the sky or a field of grass
 - Subjects that are in constant motion, such as waves and waterfalls
 - Subjects that undergo marked changes in brightness
- Exposure for the entire panorama is determined by the first frame.

Viewing Panoramas

With the panorama displayed full frame, press the focus stick (focus lever) down to start panorama playback. Vertical panoramas will scroll vertically, horizontal panoramas horizontally.

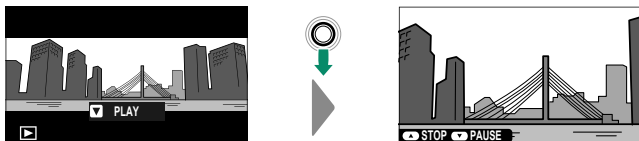

- In full-frame playback, you can use the rear command dial to zoom panoramas in or out.
- Panorama playback is controlled using the focus stick.

Focus stick (focus lever)	Full-frame playback	Panorama playback	Panorama playback paused
Up	—	End playback	
Down	Start playback	Pause playback	Resume playback
Left/right	View other pictures	Choose pan direction	Scroll panorama manually

SP SCENE POSITION / ▲ / 📷 / C+

The camera offers a choice of “scenes”, each adapted to particular shooting conditions or a specific type of subject.

- 1 Rotate the mode dial to **SP (SCENE POSITION)**.

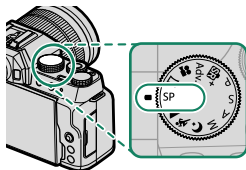



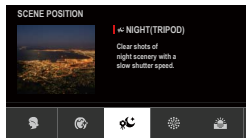









- 2 Press **MENU/OK** while the mode description is displayed.





- If the view through the lens is displayed in the LCD monitor, press **MENU/OK** and select **SHOOTING SETTING > SCENE POSITION** in the shooting menu.
- The function dial can be used to choose a scene in the shooting display.

3 Highlight one of the following options and press **MENU/OK**.

Scene	Description
 PORTRAIT	Choose for portraits.
 PORTRAIT ENHANCER	Choose for a smooth skin effect when shooting portraits. You can choose the portrait enhancement level in the touch menu.
 NIGHT (TRIPOD)	Choose this mode for slow shutter speeds when shooting at night.
 FIREWORKS	Slow shutter speeds are used to capture the expanding burst of light from a firework.
 SUNSET	Choose this mode to record the vivid colors in sunrises and sunsets.
 SNOW	Choose for crisp, clear shots that capture the brightness of scenes dominated by shining white snow.
 BEACH	Choose for crisp, clear shots that capture the brightness of sunlit beaches.
 UNDERWATER	Reduces the blue cast typically associated with underwater lighting.
 PARTY	Capture indoor background lighting under low-light conditions.
 FLOWER	Effective for taking more vivid shots of flowers.
 TEXT	Take clear pictures of text or drawings in print.
 MULTIPLE EXPOSURE	Create a photograph that combines two exposures (📖 65).
 LIGHT TRAIL	Take photographs in which light sources such as car headlights or ascending fireworks appear to be followed by trails of light.

Modes

The following scenes can be selected directly using the mode dial:

Scene	Description
 LANDSCAPE	Choose for daylight shots of buildings and landscapes.
 SPORT	Choose when photographing moving subjects.
 NIGHT	Choose for poorly lit twilight or night scenes.

Multiple Exposures

Create a photograph that combines two exposures.



- 1 Select  **MULTIPLE EXPOSURE** in the scene position menu.
- 2 Take the first shot.
- 3 Press **MENU/OK**. The first shot will be shown superimposed on the view through the lens and you will be prompted to take the second shot.



-  To return to Step 2 and retake the first shot, press the focus stick (focus lever) left.
- To save the first shot and exit without creating a multiple exposure, press **DISP/BACK**.

- 4 Take the second shot, using the first frame as a guide.
- 5 Press **MENU/OK** to create the multiple exposure, or press the focus stick left to return to Step 4 and retake the second shot.

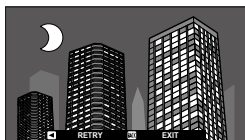
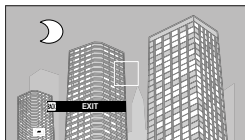

Adv. ADVANCED FILTER

Take photos with filter effects.

- 1 Rotate the mode dial to **Adv.** (**ADVANCED FILTER**).

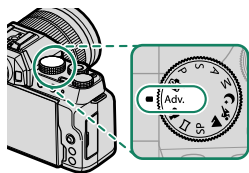



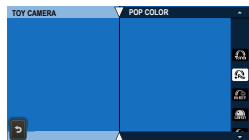

















- 2 Press **MENU/OK** while the mode description is displayed.



 If the view through the lens is displayed in the LCD monitor, press **MENU/OK** and select **SHOOTING SETTING > ADVANCED FILTER** in the shooting menu.

- 3 Highlight one of the following options and press **MENU/OK**.

Filter	Description
 CLARITY FILTER	Soften or sharpen pictures without losing definition. The strength of the effect can be adjusting using SHOOTING SETTING > CLARITY FILTER SETTING .
 TOY CAMERA	Choose for a retro toy camera effect.
 POP COLOR	Create high-contrast images with saturated colors.
 HIGH-KEY	Create bright, low-contrast images.
 LOW-KEY	Create uniformly dark tones with few areas of emphasized highlights.
 FISH-EYE	Create a distorting effect of a fisheye lens.
 DYNAMIC TONE	Dynamic tone expression is used for a fantasy effect.
 HDR ART	Create artistic effect by emphasizing tone reproduction and dynamic range.

Filter	Description
 MINIATURE	The tops and bottoms of pictures are blurred for a diorama effect.
 CROSS SCREEN	Create a star pattern where lines radiate out from bright objects. The effects of the cross screen filter can be viewed after shooting.
 RICH & FINE	Add a rich & fine effect recommend for tabletop photography.
 MONOCHROME(NIR)	Monochrome photography as taken by Near-infrared camera.
 PARTIAL COLOR (RED)	Areas of the image that are the selected color are recorded in that color. All other areas of the image are recorded in black-and-white.
 PARTIAL COLOR (ORANGE)	
 PARTIAL COLOR (YELLOW)	
 PARTIAL COLOR (GREEN)	
 PARTIAL COLOR (BLUE)	
 PARTIAL COLOR (PURPLE)	
 FOG REMOVE	Create clearer image by removing fog factor.
 SOFT FOCUS	Create a look that is evenly soft throughout the whole image.

 Depending on the subject and camera settings, images may in some cases be grainy or vary in brightness or hue.

Autofocus

Take pictures using autofocus.



- 1 Use **AF/MF** **AF/MF SETTING** > **FOCUS MODE** to choose a focus mode (📖 69).
- 2 Use **AF/MF** **AF/MF SETTING** > **AF MODE** to choose an AF mode (📖 71).
- 3 Select **AF/MF** **AF/MF SETTING** > **FOCUS AREA** and choose the position and size of the focus frame (📖 73).

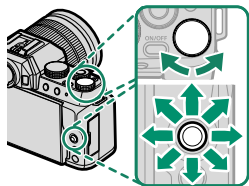



- 4 Take pictures.

Focus Mode

Choose how the camera focuses.

- 1 Press **MENU/OK** to display the menus.
- 2 Select **AF/MF SETTING > FOCUS MODE** in the shooting menu.
- 3 Choose from the following options:

Mode	Description
 MANUAL FOCUS	Focus manually using the lens focus ring. Choose for manual control of focus or in situations in which the camera is unable to focus using autofocus (📖 77).
 CONTINUOUS AF	Focus is continually adjusted to reflect changes in the distance to the subject while the shutter button is pressed halfway. Use for subjects that are in motion.
 SINGLE AF	Focus locks while the shutter button is pressed halfway. Choose for stationary subjects.

- Regardless of the option selected, manual focus will be used when the lens is in manual focus mode.
- If **ON** is selected for **AF/MF SETTING > PRE-AF**, focus will be adjusted continuously in modes **AF-S** and **AF-C** even when the shutter button is not pressed.

The Focus Indicator

Focus status is shown by the focus indicator.

Focus indicator	Focus status
()	Camera focusing.
● (lights green)	Subject in focus; focus locked (focus mode AF-S).
● (lights green)	Subject in focus (focus mode AF-C).
○ (blinks white)	Focus is automatically adjusted for changes in distance to subject.
MF	Manual focus (focus mode MF).

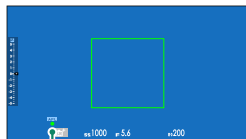

Focus indicator







Autofocus Options (AF Mode)

Choose how the camera focuses in modes **[AF-S]** and **[AF-C]**.



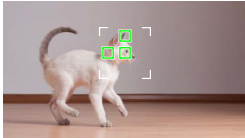

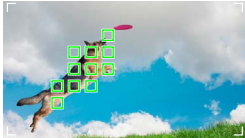



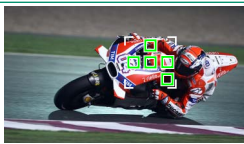

- 1 Press **MENU/OK** and go to the shooting menu.
- 2 Select **[AF] AF/MF SETTING > AF MODE**.
- 3 Choose an AF mode.

How the camera focuses depends on the focus mode.

Focus Mode **[AF-S]** (SINGLE AF)

Option	Description	Sample image
 SINGLE POINT	Camera focuses on subject in selected focus point. Use for pin-point focus on selected subject.	
 ZONE	Camera focuses on subject in selected focus zone. Focus zones include multiple focus points, making it easier to focus on subjects in motion.	
 WIDE	Camera focuses automatically on high-contrast subjects; display shows areas in focus.	
 ALL	Rotate the rear command dial in the focus-point selection display (📖 74, 75) to cycle through AF modes in the following order: [] SINGLE POINT , [] ZONE , and [] WIDE .	

Focus Mode (CONTINUOUS AF)

Option	Description	Sample image
 SINGLE POINT	Focus tracks subject at selected focus point. Use for subjects moving toward or away from camera.	
 ZONE	Focus tracks subject in selected focus zone. Use for subjects that are moving fairly predictably.	
 TRACKING	Focus tracks subjects moving through wide area of frame.	
 ALL	Rotate the rear command dial in the focus-point selection display ( 74, 75) to cycle through AF modes in the following order:  SINGLE POINT ,  ZONE , and  TRACKING .	

Focus-Point Selection

Choose a focus point for autofocus.

Viewing the Focus-Point Display







- 1 Press **MENU/OK** and go to the shooting menu.
- 2 Select **AF/MF SETTING > FOCUS AREA** to view the focus-point display.
- 3 Use the focus stick (focus lever) and rear command dial to choose a focus area.

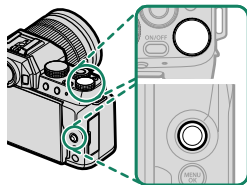







 The focus point can also be selected using touch controls ( 19).

Selecting a Focus Point

Use the focus stick (focus lever) to choose the focus point and the rear command dial to choose the size of the focus frame. The procedure varies with the option selected for AF mode.



AF mode	Focus stick		Rear command dial
	 Tilt	 Press	 Rotate
	Select focus point	Select center focus point	Choose from 6 frame sizes
			Choose from 3 frame sizes
			—

- Manual focus-point selection is not available when  **WIDE/TRACKING** is selected in focus mode .
- If  **ALL** is selected for AF mode, you can rotate the rear command dial in the focus-point selection display to cycle through AF modes in the following order:  **SINGLE POINT** (6 frame sizes),  **ZONE** (3 frame sizes), and either  **WIDE** (focus mode ) or  **TRACKING** (focus mode 

5

The Focus-Point Display

The focus-point display varies with the option selected for AF mode.

Focus frames are shown by small squares (□), focus zones by the large squares.

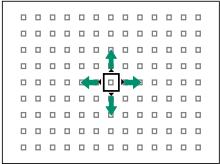
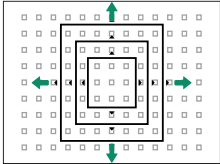
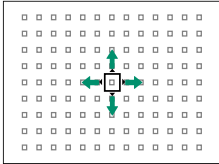
AF mode		
□ SINGLE POINT	[L1] ZONE	[L2] WIDE/TRACKING
		
Number of points available can be selected using AF/MF SETTING > NUMBER OF FOCUS POINTS.	Choose from zones with 7×7 , 5×5 , or 3×3 focus points.	Position focus frame over subject you want to track.

Autofocus

Although the camera boasts a high-precision autofocus system, it may be unable to focus on the subjects listed below.

- Very shiny subjects such as mirrors or car bodies.
- Subjects photographed through a window or other reflective object.
- Dark subjects and subjects that absorb rather than reflect light, such as hair or fur.
- Insubstantial subjects, such as smoke or flame.
- Subjects that show little contrast with the background.
- Subjects positioned in front of or behind a high-contrast object that is also in the focus frame (for example, a subject photographed against a backdrop of highly contrasting elements).

Checking Focus

To zoom in on the current focus area for precise focus, press the center of the focus stick (focus lever). Press again to zoom in further and a third time to cancel zoom.

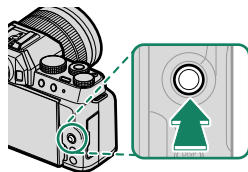

Normal display



Focus zoom

- In focus mode **[AF-S]**, zoom can be adjusted by rotating the rear command dial.
- In focus mode **[AF-S]**, select **[] SINGLE POINT** for **AF MODE**.
- Focus zoom is not available in focus mode **[AF-C]** or when **[AF-ON] AF/MF SETTING > PRE-AF** is on.
- Use **[] BUTTON/DIAL SETTING > FOCUS LEVER SETTING** to change the function performed by the center of the focus stick (focus lever). **[] BUTTON/DIAL SETTING > FUNCTION (Fn) SETTING** can also be used to assign focus zoom to other controls (186).

Manual Focus

Adjust focus manually.



- 1 Select **MANUAL FOCUS** for **AF/MF SETTING > FOCUS MODE**.

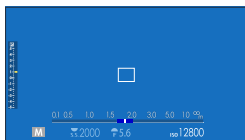

- 2 Focus manually using the lens focus ring. Rotate the ring left to reduce the focus distance, right to increase.

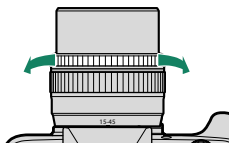

- 3 Take pictures.

- Use **BUTTON/DIAL SETTING > FOCUS RING** to reverse the direction of rotation of the focus ring.
- Regardless of the option selected, manual focus will be used when the lens is in manual focus mode.
- To display a **MF** indicator in manual focus mode, select **FOCUS MODE** in the **SCREEN SET-UP > DISP. CUSTOM SETTING** list and use the **DISP/BACK** button to display standard indicators.

Checking Focus

A variety of options are available for checking focus in manual focus mode.

The Manual Focus Indicator

The manual focus indicator indicates how closely the focus distance matches the distance to the subject in the focus brackets. The white line indicates the distance to the subject in the focus area (in meters or feet according to the option selected for **SCREEN SET-UP > FOCUS SCALE UNITS** in the setup menu), the blue bar the depth of field, or in other words the distance in front of and behind the subject that appears to be in focus.

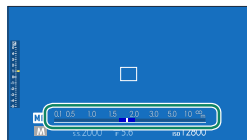

Focus distance
(white line)

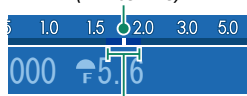

Depth of field

If both **AF DISTANCE INDICATOR** and **MF DISTANCE INDICATOR** are selected in the **SCREEN SET-UP > DISP. CUSTOM SETTING** list, the manual focus indicator can also be viewed using the depth-of-field indicator in the standard display. Use the **DISP/BACK** button to display standard indicators.

Focus Zoom

If **ON** is selected for **AF/MF SETTING > FOCUS CHECK**, the camera will automatically zoom in on the selected focus area when the focus ring is rotated (73). Zoom can be adjusted by rotating the rear command dial. Press the center of the focus stick (focus lever) to exit zoom.

The focus stick can be used to choose the focus area while focus zoom is in effect.

Focus Peaking

Select **FOCUS PEAK HIGHLIGHT** for **AF/MF SETTING > MF ASSIST** to highlight high-contrast outlines. When focusing, rotate the focus ring until the subject is highlighted.

Exposure Compensation

Adjust exposure.



Rotate the rear command dial to adjust exposure.

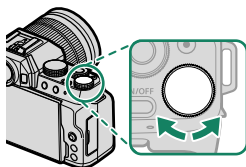

 The amount of compensation available varies with the shooting mode.

Focus/Exposure Lock

Compose photographs with off-center subjects.



- 1 Position the subject in the focus frame and press the shutter button halfway to lock focus and exposure. Focus and exposure will remain locked while the shutter button is pressed halfway (AF/AE lock).

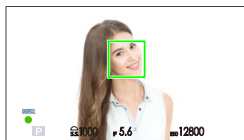

- 2 Press the button all the way down.

The Function Buttons

Focus and/or exposure lock can be assigned to a function button.

Option	Description
AE-LOCK	Pressing the button locks exposure.
AF-LOCK	Pressing the button locks focus.
AE/AF LOCK	Pressing the button locks both focus and exposure.

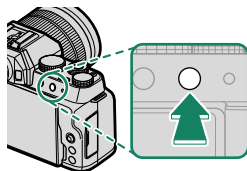

- At default settings, **AF-LOCK** is assigned to the **Fn2** button (📖 186).
- When a function button is used for focus or exposure lock, the affected setting will remain locked even when the shutter button is pressed halfway.

WB White Balance

For natural colors, choose a white balance option that matches the light source.



- 1 Press **MENU/OK** to display the shooting menu.
- 2 Highlight **IMAGE QUALITY SETTING > WHITE BALANCE** in the shooting menu and press **MENU/OK** to view white balance options.



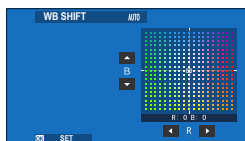





- 3 Highlight a white balance option.
 - Press **MENU/OK** to view a **WB SHIFT** display where white balance can be fine-tuned using the focus stick (focus lever).
 - Press **DISP/BACK** to select the highlighted option and exit without applying fine-tuning.





 At default settings, white balance can also be accessed via the **T.B. Fn1** button in the touch menu (189). Tap the **T.B. Fn1** button and adjust white balance using touch controls.

WHITE BALANCE

The following white balance options are available.

Option	Description
AUTO	White balance is adjusted automatically.
	Measure a value for white balance.
K	Choose a color temperature.
	For subjects in direct sunlight.
	For subjects in the shade.
	Use under "daylight" fluorescent lights.
	Use under "warm white" fluorescent lights.
	Use under "cool white" fluorescent lights.
	Use under incandescent lighting.
	Reduces the blue cast typically associated with underwater lighting.

-  • Results vary with shooting conditions. Play pictures back after shooting to check colors.
- White balance is adjusted for flash lighting only in **AUTO** and  modes. Turn the flash off using other white balance options.

Custom White Balance

Choose  to adjust white balance for unusual lighting conditions. White balance measurement options will be displayed; frame a white object so that it fills the display and press the shutter button



all the way down to measure white balance (to select the most recent custom value and exit without measuring white balance, press **DISP/BACK**, or press **MENU/OK** to select the most recent value and display the fine-tuning dialog).

- If **“COMPLETED!”** is displayed, press **MENU/OK** to set white balance to the measured value.
- If **“UNDER”** is displayed, raise exposure compensation and try again.
- If **“OVER”** is displayed, lower exposure compensation and try again.



K: Color Temperature

Selecting **K** in the white balance menu displays a list of color temperatures; highlight a color temperature and press **MENU/OK** to select the highlighted option and display the fine-tuning dialog.

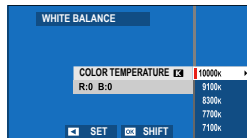

Color Temperature

Color temperature is an objective measure of the color of a light source, expressed in Kelvin (K). Light sources with a color temperature close to that of direct sunlight appear white; light sources with a lower color temperature have a yellow or red cast, while those with a higher color temperature are tinged with blue. You can match color temperature to the light source, or choose options that differ sharply from the color of the light source to make pictures “warmer” or “colder.”



Using the Self Timer

Use the timer for group- or self-portraits, to prevent blur caused by camera shake, or to release the shutter automatically when selected conditions are met.



- 1 Press **MENU/OK** to display the shooting menu.
- 2 Select **SHOOTING SETTING > SELF-TIMER** in the shooting menu to display self-timer options.
- 3 Highlight one of the following options and press **MENU/OK**.

Option		Option	
2 SEC	86	BUDDY	87
10 SEC	86	GROUP	88
FACE AUTO SHUTTER	86	OFF	—
SMILE	87		



- Stand behind the camera when using the shutter button. Standing in front of the lens can interfere with focus and exposure.
- The self-timer turns off automatically when the camera is turned off.





- To stop the timer before the picture is taken, press **DISP/BACK**.
- Selecting **FACE AUTO SHUTTER**, **SMILE**, **BUDDY**, or **GROUP** sets **AF/MF SETTING > FACE/EYE DETECTION SETTING** to **FACE ON/EYE OFF**. The original setting is restored when the self timer is turned off.

2 SEC/10 SEC

The shutter is released 2 or 10 seconds after the shutter button is pressed.

- 1 Select either of the following options in the self-timer menu.

Option	Description
 2 SEC	The shutter is released two seconds after the shutter button is pressed. Use to reduce blur caused by the camera moving when the shutter button is pressed. The self-timer lamp blinks as the timer counts down.
 10 SEC	The shutter is released ten seconds after the shutter button is pressed. Use for photographs in which you wish to appear yourself. The self-timer lamp blinks immediately before the picture is taken.

- 2 Press the shutter button all the way down to start the timer. A count-down timer will appear in the display; the picture will be taken when the timer expires.

FACE AUTO SHUTTER

The picture will be taken when the camera detects a portrait subject facing the lens.

- 1 Select  (**FACE AUTO SHUTTER**) in the self-timer menu.
- 2 Frame a portrait subject in the display. The camera will initiate face detection and release the shutter when the subject is facing the lens.

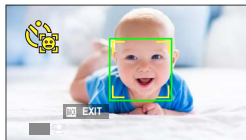



 The camera may fail to detect subjects who are not facing the camera or whose eyes are hidden.

SMILE

The camera releases the shutter when the subject smiles.

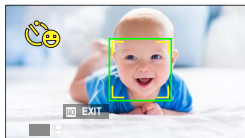
- 1 Select  (**SMILE**) in the self-timer menu.
- 2 Frame portrait subjects in the display. The camera will initiate face detection and release the shutter when any of the subjects smiles.



 The camera may fail to detect subjects who are not facing the camera or whose eyes are obscured by hair or other objects.

BUDDY

The camera takes a picture when it detects two subjects close together.

- 1 Select  (**BUDDY**) in the self-timer menu.
- 2 Choose how close the subjects must be together before the timer starts (the required degree of closeness is shown by heart icons in the shooting display: the more hearts, the closer together the subjects must be).

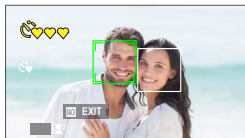



- **LV.1 (NEAR):** The timer starts when the subjects are close enough to link hands.
- **LV.2 (CLOSE UP):** The timer starts when the subjects are shoulder-to-shoulder.
- **LV.3 (SUPER CLOSE):** The timer starts when the subjects are cheek-to-cheek.

 The timer starts only when the subjects are sufficiently close together; the shutter is released one second later.

GROUP

The camera takes a picture when it detects the selected number of portrait subjects.

1 Select  (**GROUP**) in the self-timer menu.

2 Select the desired number of subjects (1 to 4) (the number of subjects is indicated by  icons in the shooting display). The timer starts only when the selected number of subjects is in the frame; the shutter is released two seconds later.

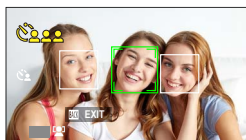



Bracketing

Automatically vary settings over a series of pictures.



- 1 Press the (drive) button to display drive mode options.

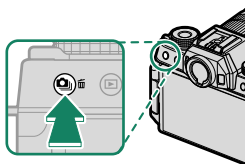

- 2 Press the focus stick (focus lever) up or down to highlight one of the following:

Option		Option	
AE BKT	90	WHITE BALANCE BKT	90
ISO BKT	90	DYNAMIC RANGE BKT	91
FILM SIMULATION BKT	90	HDR	91

- 3 Press the focus stick left or right to highlight the desired bracketing settings.

- Bracketing settings for AE BKT are selected using SHOOTING SETTING > AE BKT SETTING.
- Bracketing settings for FILM SIMULATION BKT are selected using SHOOTING SETTING > FILM SIMULATION BKT.

- 4 Press **MENU/OK** to select.

- 5 Take pictures.

AE BKT

Use  **SHOOTING SETTING > AE BKT SETTING** to choose the bracketing amount and number of shots. Each time the shutter button is pressed, the camera will take the specified number of shots: one using the metered value for exposure and the others over- or under-exposed by multiples of the selected bracketing amount.

 Regardless of the bracketing amount, exposure will not exceed the limits of the exposure metering system.

ISO BKT

Select a bracketing amount (± 1 , $\pm \frac{2}{3}$, or $\pm \frac{1}{3}$). Each time the shutter is released, the camera will take a picture at the current sensitivity and process it to create two additional copies, one with sensitivity raised and the other with sensitivity lowered by the selected amount.

FILM SIMULATION BKT

Each time the shutter is released, the camera takes one shot and processes it to create a total of three copies with different film simulation settings, chosen using the  **SHOOTING SETTING > FILM SIMULATION BKT** option in the shooting menu.

WHITE BALANCE BKT

Select a bracketing amount (± 1 , ± 2 , or ± 3). Each time the shutter is released, the camera takes one shot and processes it to create three copies: one at the current white balanced setting, one with fine-tuning increased by the selected amount, and another with fine-tuning decreased by the selected amount.

DYNAMIC RANGE BKT

Each time the shutter button is pressed, the camera takes three shots with different dynamic ranges: 100% for the first, 200% for the second, and 400% for the third.

 While dynamic range bracketing is in effect, sensitivity will be restricted to a minimum of ISO 800 (or to a minimum of ISO 200 to 800 when an auto option is selected for sensitivity); the sensitivity previously in effect is restored when bracketing ends.

HDR

Each time the shutter button is pressed, the camera takes multiple shots at different exposures and combines them into a single high-dynamic-range image, reducing loss of detail in highlights and shadows. Choose the amount the camera varies exposure from **AUTO**, **1.0 EV**, **1.5 EV**, **2.0 EV**, **2.5 EV**, and **3.0 EV**.

 Keep the camera steady. If the camera is moved or the subject changes during shooting, the shots may be recorded separately instead of being combined into a single image. The camera may fail to record an image if the subject moves during shooting.





Continuous Shooting (Burst Mode)

Capture motion in a series of pictures.



- 1 Press the  (drive) button to display drive mode options.



- 2 Press the focus stick (focus lever) up or down to select  **CONTINUOUS**.
- 3 Press the focus stick left or right to choose the frame rate ( **HIGH** or  **LOW**).
- 4 Press **MENU/OK** to save changes and exit the drive-mode menu.
- 5 Take pictures.
Keep the shutter button pressed to take pictures at the rate selected in Step 3.



Shooting ends when the shutter button is released or the memory card is full.

- ❗ • If file numbering reaches 999 before shooting is complete, the remaining pictures will be recorded to a new folder.
- Shooting ends when the memory card is full; the camera will record all photos shot to that point. Burst shooting may not begin if the space available on the memory card is insufficient.
- Frame rates may slow as more shots are taken.
- Frame rate varies with the scene, shutter speed, sensitivity, and focus mode.
- Depending on shooting conditions, frame rates may slow.
- The flash cannot be used.
- Recording times may increase during burst shooting.

Using the Flash





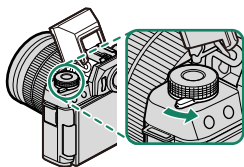

Use the built-in flash for additional lighting when shooting at night or indoors under low light.





- 1 Slide the  (flash pop-up) lever as shown.





- 2 Press **MENU/OK** to display the shooting menu.
- 3 Highlight  **FLASH SETTING > FLASH MODE** in the shooting menu and press **MENU/OK** to view flash options.
- 4 Highlight one of the following options and press **MENU/OK**.

Mode	Description
AUTO AUTO FLASH  RED EYE REDUCTION*	The flash fires when required. Recommended in most situations.
 FORCED FLASH  FORCED FLASH*	The flash fires whenever a picture is taken. Use for backlit subjects or for natural coloration when shooting in bright light.
 SLOW SYNCHRO  RED EYE & SLOW*	Capture both the main subject and the background under low light (note that brightly lit scenes may be overexposed).
 2ND CURTAIN SYNC.  2ND CURTAIN SYNC.*	The flash fires immediately before the shutter closes.

Mode	Description
 COMMANDER	The built-in flash can be used to control optional remote flash units.
 SUPPRESSED FLASH	The flash does not fire even when the subject is poorly lit. A tripod is recommended.

* Red-eye removal is available in these modes when Intelligent Face Detection is active and red-eye removal is on. Red-eye removal minimizes “red-eye” caused when light from the flash is reflected from the subject’s retinas.

-  Depending on the distance to the subject, some lenses may cast shadows in photos taken with the flash.
- The flash may contact accessories mounted on the hot shoe. If necessary, remove accessories before raising the flash.

-  If  is displayed when the shutter button is pressed halfway, the flash will fire when the photo is taken.
- Except in commander mode, the flash may fire several times with each shot. Do not move the camera until shooting is complete.

Flash Sync Speed

The flash will synchronize with the shutter at shutter speeds of $\frac{1}{180}$ s or slower.

Optional Flash Units from Fujifilm

The camera can be used with optional Fujifilm shoe-mounted flash units.

Third-Party Flash Units

Do not use third-party flash units that apply over 300 V to the camera hot shoe.

Self-Portraits (Selfies)

To shoot a self-portrait, rotate the LCD monitor as shown.

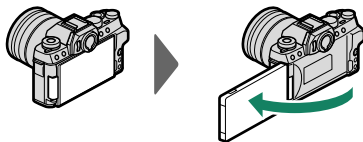

- Rotating the LCD monitor 180° automatically sets **AF/MF SETTING** > **FACE/EYE DETECTION SETTING** to **FACE ON/EYE AUTO**.
- Regardless of the option selected for **SCREEN SET-UP** > **IMAGE DISP.**, pictures will be displayed for 1.5 seconds after shooting.

The Self-Portrait Display

When rotated to the self-portrait position, the LCD monitor shows a mirror image of the view through the lens.

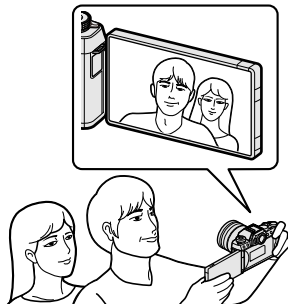

6

The Shooting Menus



IMAGE QUALITY SETTING

Adjust image quality settings.

To display image quality settings, press **MENU/OK** in the shooting display and select the **I.Q.** (**IMAGE QUALITY SETTING**) tab.



The options available vary with the shooting mode selected.

IMAGE SIZE

Choose the size and aspect ratio at which still pictures are recorded.

Option (Image size)

L 4:3 (5328 × 4000)	L 3:2 (6000 × 4000)	L 16:9 (6000 × 3376)	L 1:1 (4000 × 4000)
M 4:3 (3712 × 2784)	M 3:2 (4240 × 2832)	M 16:9 (4240 × 2384)	M 1:1 (2832 × 2832)
S 4:3 (2656 × 1992)	S 3:2 (3008 × 2000)	S 16:9 (3008 × 1688)	S 1:1 (2000 × 2000)



IMAGE SIZE is not reset when the camera is turned off or another shooting mode is selected.

IMAGE QUALITY

Choose a file format and compression ratio.

Option	Description
FINE	Lower compression ratios are used for higher-quality images.
NORMAL	Higher compression ratios are used to increase the number of images that can be stored.
FINE + RAW	Record both RAW and fine-quality JPEG images.
NORMAL + RAW	Record both RAW and normal-quality JPEG images.
RAW	Record RAW images only.













The Function Buttons

To toggle RAW image quality on or off for a single shot, assign **RAW** to a function button (☰ 186). Press the button once to select the option in the right column, again to return to the original setting (left column).

Option currently selected for IMAGE QUALITY	Option selected by pressing function button to which RAW is assigned
FINE	FINE + RAW
NORMAL	NORMAL + RAW
FINE + RAW	FINE
NORMAL + RAW	NORMAL
RAW	FINE

FILM SIMULATION

Simulate the effects of different kinds of film, including black-and-white (with or without color filters). Choose a palette according to your subject and creative intent.

Option	Description
 PROVIA/STANDARD	Standard color reproduction. Suited to a wide range of subjects, from portraits to landscapes.
 Velvia/VIVID	A high-contrast palette of saturated colors, suited to nature photos.
 ASTIA/SOFT	Enhances the range of hues available for skin tones in portraits while preserving the bright blues of daylight skies. Recommended for outdoor portrait photography.
 CLASSIC CHROME	Soft color and enhanced shadow contrast for a calm look.
 PRO Neg. Hi	Offers slightly more contrast than  (PRO Neg. Std.). Recommended for outdoor portrait photography.
 PRO Neg. Std	A soft-toned palette. The range of hues available for skin tones is enhanced, making this a good choice for studio portrait photography.
 MONOCHROME	Take pictures in standard black and white.
 MONOCHROME + Ye FILTER	Take black-and-white pictures with slightly increased contrast. This setting also slightly tones down the brightness of the sky.
 MONOCHROME + R FILTER	Take black-and-white pictures with increased contrast. This setting also tones down the brightness of the sky.
 MONOCHROME + G FILTER	Soften skin tones in black-and-white portraits.
 SEPIA	Take pictures in sepia.



- Film simulation options can be combined with tone and sharpness settings.
- For more information, visit:
https://fujifilm-x.com/global/tag/the-world-of-film-simulation/?post_type=xstories
- At default settings, film simulation is assigned to the touch menu **T.B. Fn2** button (📖 189).

PORTRAIT ENHANCER LV

Choose the portrait enhancement level using a slider while previewing the effect in the display.



! Select **FACE DETECTION ON** for **AF/MF SETTING > FACE/EYE DETECTION SETTING** when adjusting the portrait enhancement level.

BRIGHT MODE

Select **ON** to enable bright mode when shooting in **SR+**. Use bright mode to better capture details in highlights and shadows.

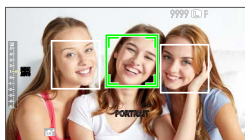



Options

ON

OFF

DYNAMIC RANGE





Control contrast. Choose lower values to increase contrast when shooting indoors or under overcast skies, higher values to reduce loss of detail in highlights when photographing high-contrast scenes. Higher values are recommended for scenes that include both sunlight and deep shade, for such high-contrast subjects as sunlight on water, brightly-lit autumn leaves, and portraits taken against a blue sky, and for white objects or people wearing white.

Options			
AUTO	 100%	 200%	 400%



Mottling may appear in pictures taken at higher values. Choose a value according to the scene.



- If **AUTO** is selected, the camera will automatically choose either  **100%** or  **200%** according to the subject and shooting conditions. Shutter speed and aperture will be displayed when the shutter button is pressed halfway.
-  **200%** is available at sensitivities of from ISO 400 to ISO 12800,  **400%** at sensitivities of from ISO 800 to 12800.

WHITE BALANCE

For natural colors, choose a white balance option that matches the light source (📖 81).

HIGHLIGHT TONE

Adjust the appearance of highlights.

Options				
-2	-1	0	+1	+2

SHADOW TONE

Adjust the appearance of shadows.

Options				
-2	-1	0	+1	+2

COLOR

Adjust color density.

Options				
-2	-1	0	+1	+2

SHARPNESS

Sharpen or soften outlines.

Options				
-2	-1	0	+1	+2

NOISE REDUCTION

Reduce noise in pictures taken at high sensitivities.

Options				
-2	-1	0	+1	+2

LONG EXPOSURE NR

Select **ON** to reduce mottling in long time-exposures.

Options	
ON	OFF

COLOR SPACE

Choose the gamut of colors available for color reproduction.

Option	Description
sRGB	Recommended in most situations.
Adobe RGB	For commercial printing.



AF/MF SETTING

Adjust focus settings.

To display focus settings, press **MENU/OK** in the shooting display and select the **AF/MF** (**AF/MF SETTING**) tab.

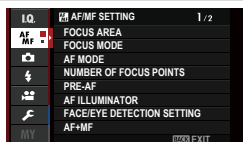

The options available vary with the shooting mode selected.

FOCUS AREA

Choose the focus area for autofocus, manual focus, and focus zoom (📖 73).

FOCUS MODE

Choose how the camera focuses (📖 69).

AF MODE

Choose how the camera focuses in modes **AF-S** and **AF-C** (📖 71).

NUMBER OF FOCUS POINTS

Choose the number of focus points available for focus-point selection in manual focus mode or when **SINGLE POINT** is selected for **AF MODE**.

Option	Description
117 POINTS (9 × 13)	Choose from 117 focus points arranged in a 9- by 13-point grid.
425 POINTS (17 × 25)	Choose from 425 focus points arranged in a 17- by 25-point grid.

PRE-AF

If **ON** is selected, the camera will continue to adjust focus even when the shutter button is not pressed halfway. The camera adjusts focus continuously, allowing it to focus faster when the shutter button is pressed halfway. Choosing this option helps prevent missed shots.



Options	
ON	OFF

 Choosing **ON** increases the drain on the battery.

AF ILLUMINATOR

If **ON** is selected, the AF-assist illuminator will light to assist autofocus.

Options	
ON	OFF

-  The AF-assist illuminator turns off automatically when **OFF** is selected for  **USER SETTING** > **SOUND & FLASH** in the setup menu.
- The camera may be unable to focus using the AF-assist illuminator in some cases.
- If the camera is unable to focus, try increasing the distance to the subject.
- Avoid shining the AF-assist illuminator directly into your subject's eyes.

FACE/EYE DETECTION SETTING

Intelligent Face Detection sets focus and exposure for human faces anywhere in the frame, preventing the camera from focusing on the background in group portraits. Choose for shots that emphasize portrait subjects. You can also choose whether the camera detects and focuses on either the left or right eye when Intelligent Face Detection is on.

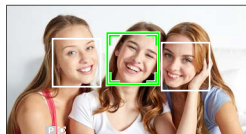

Option	Description
FACE DETECTION ON	<p>Adjust settings for Intelligent Face Detection. You can also adjust eye detection settings.</p> <ul style="list-style-type: none"> • EYE OFF: Intelligent Face Detection only. • EYE AUTO: The camera automatically chooses which eye to focus on when a face is detected. • RIGHT EYE PRIORITY: The camera focuses on the right eye of subjects detected using Intelligent Face Detection. • LEFT EYE PRIORITY: The camera focuses on the left eye of subjects detected using Intelligent Face Detection.
OFF	Intelligent Face Detection and eye priority off.

- If the subject moves as the shutter button is pressed, the face may not be in the area indicated by the green border when the picture is taken.
- In some modes, the camera may set exposure for the frame as a whole rather than the portrait subject.
- **FACE DETECTION ON** > **EYE AUTO** is selected automatically in **SR+** (**ADVANCED SR AUTO**) mode and when **Portrait** or **Portrait Enhancer** is selected in **SP** mode.

- The face selected by the camera is indicated by a green border.
- If multiple faces are detected, the subject closest to the center of the frame will be indicated by a green border and the remaining subjects by white borders.
- Faces can be detected with the camera in vertical or horizontal orientation.
- If the camera is unable to detect the subject's eyes because they are hidden by hair, glasses, or other objects, the camera will instead focus on faces.

AF+MF

If **ON** is selected in focus mode  and focus has been locked (whether by pressing the shutter button halfway or by other means), focus lock can be ended and focus adjusted manually by rotating the focus ring.

Options	
ON	OFF

- ❗ Lenses with a focus distance indicator must be set to manual focus mode (MF) before this option can be used. Selecting MF disables the focus distance indicator.
- If the lens is equipped with a focus distance indicator, set the focus ring to the center, as the camera may fail to focus if the ring is set to infinity or the minimum focus distance.

 To assist focus using focus peaking, select **FOCUS PEAK HIGHLIGHT** for **MF ASSIST**.

AF + MF Focus Zoom

When **ON** is selected for  **AF/MF SETTING** > **FOCUS CHECK** and **SINGLE POINT** selected for **AF MODE**, focus zoom can be used to zoom in on the selected focus area.

MF ASSIST

Choose how focus is displayed in manual focus mode.

Option	Description
STANDARD	Focus is displayed normally.
FOCUS PEAK HIGHLIGHT	The camera heightens high-contrast outlines. Choose a color and peaking level.

FOCUS CHECK

If **ON** is selected, the display will automatically zoom in on the selected focus area when the focus ring is rotated in manual focus mode.

Options	
ON	OFF

- Press the focus stick (focus lever) to cancel focus zoom.
- The zoom position is centered on the current focus area and changes when the focus area is changed.

INTERLOCK SPOT AE & FOCUS AREA

Select **ON** to meter the current focus frame when **SINGLE POINT** is selected for **AF MODE** and **SPOT** is selected for **PHOTOMETRY**.

Options	
ON	OFF

RELEASE/FOCUS PRIORITY

Choose how the camera focuses in focus mode **AF-S** (AF-S) or **AF-C** (AF-C).

Option	Description
RELEASE	Shutter response is prioritized over focus. Pictures can be taken when the camera is not in focus.
FOCUS	Focus is prioritized over shutter response. Pictures can be only taken when the camera is in focus.

TOUCH SCREEN MODE

Choose whether touch controls can be used to select the focus area or release the shutter (21).



SHOOTING SETTING

Adjust shooting options.

To display shooting options, press **MENU/OK** in the shooting display and select the  (**SHOOTING SETTING**) tab.

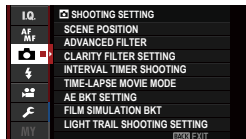

The options available vary with the shooting mode selected.

SCENE POSITION

Choose a scene for **SP** mode ( 63).

ADVANCED FILTER

Choose an advanced filter for **Adv.** mode ( 66).

CLARITY FILTER SETTING

Adjust the strength of the **Adv.** mode clarity filter. The higher the value, the greater the clarity.

Options				
-2	-1	0	+1	+2

INTERVAL TIMER SHOOTING

Configure the camera to take photos automatically at a preset interval. If desired, frames shot using interval timer shooting can be joined to form a time-lapse movie.

- 1 Highlight **SHOOTING SETTING > INTERVAL TIMER SHOOTING** in the shooting menu and press **MENU/OK**.

- 2 Use the focus stick (focus lever) to choose the interval and number of shots. Press **MENU/OK** to proceed.

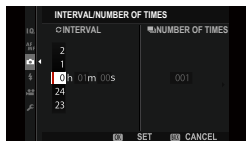

- 3 Highlight one of the following recording types and press **MENU/OK**.

- **STILL**: Each photo is recorded separately.
- **STILL+TIME-LAPSE MOVIE**: Each photo is recorded separately; in addition, the entire sequence is recorded as a time-lapse movie.

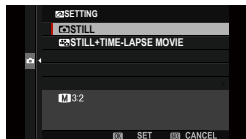

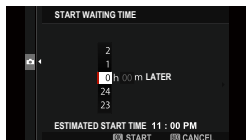

 The frame size and rate for the time-lapse movie can be selected using **TIME-LAPSE MOVIE MODE** before shooting begins.

- 4 Use the focus stick to choose the starting time and then press **MENU/OK**.

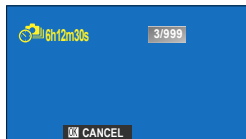

- 5 Shooting will start automatically.



 Interval timer photography cannot be used at a shutter speed of “bulb”, during panorama or multiple exposure photography, or when **HDR ART** is selected in advanced filter mode. In burst mode, only one picture will be taken each time the shutter is released.

-  • Use of a tripod is recommended.
- Check the battery level before starting. We recommend using an optional AC-9V AC power adapter and CP-W126 DC coupler.
 - The display turns off between shots and lights a few seconds before the next shot is taken.
 - The display can be activated at any time by pressing the shutter button.

TIME-LAPSE MOVIE MODE

Choose the frame size and rate for time-lapse movies.

Option	Frame size	Rate
4K 29.97P ¹	3840 × 2160 (4K)	29.97 fps
4K 25P ¹		25 fps
4K 24P ¹		24 fps
4K 23.98P ¹		23.98 fps
FHD 59.94P	1920 × 1080 (Full HD)	59.94 fps
FHD 50P		50 fps
FHD 29.97P		29.97 fps
FHD 25P		25 fps
FHD 24P		24 fps
FHD 23.98P		23.98 fps
HD 59.94P	1280 × 720 (HD)	59.94 fps
HD 50P		50 fps
HD 29.97P		29.97 fps
HD 25P		25 fps
HD 24P		24 fps
HD 23.98P		23.98 fps
SFHD 59.94P	1080 × 1080 (Full HD)	59.94 fps
SFHD 50P		50 fps
SFHD 29.97P		29.97 fps
SFHD 25P		25 fps
SFHD 24P		24 fps
SFHD 23.98P		23.98 fps
SFHD 59.94P	720 × 720 (HD)	59.94 fps
SFHD 50P		50 fps
SFHD 29.97P		29.97 fps
SFHD 25P		25 fps
SFHD 24P		24 fps
SFHD 23.98P		23.98 fps

¹ Use a memory card with a UHS speed class of 3 or better when recording time-lapse movies that will be viewed on the camera.

AE BKT SETTING

Adjust exposure bracketing settings (📖 90).

FRAMES/STEP SETTING

Choose the number of shots in the bracketing sequence and the amount exposure is varied with each shot.

Option	Description
FRAMES	Choose the number of shots in the bracketing sequence.
STEP	Choose the amount exposure is varied with each shot.

1 FRAME/CONTINUOUS

Choose whether the shots in the bracketing sequence are taken one at a time or in a single burst.

Option	Description
1 FRAME	The shots in the bracketing sequence are taken one at a time.
CONTINUOUS	The shots in the bracketing sequence are taken in a single burst.

SEQUENCE SETTING

Choose the order in which the shots are taken.

Option	Description
0 → + → -	The first shot is taken at current exposure settings and exposure compensation is then modified over the succeeding shots, proceeding in order from the highest to the lowest value.
0 → - → +	The first shot is taken at current exposure settings and exposure compensation is then modified over the succeeding shots, proceeding in order from the lowest to the highest value.
- → 0 → +	Shooting proceeds in order from the lowest to the highest value.
+ → 0 → -	Shooting proceeds in order from the highest to the lowest value.

FILM SIMULATION BKT

Choose the three film simulation types used for film simulation bracketing (📖 90, 100).

Options		
PROVIA/STANDARD	Velvia/VIVID	ASTIA/SOFT
CLASSIC CHROME	PRO Neg. Hi	PRO Neg. Std
MONOCHROME	MONOCHROME + Ye FILTER	MONOCHROME + R FILTER
MONOCHROME + G FILTER		SEPIA

LIGHT TRAIL SHOOTING SETTING

Adjust light trail settings (📖 64).

Long Exposure setting

Choose the maximum exposure time.

Options			
30 MIN	1 HOUR	3 HOUR	6 HOUR

RELEASE TYPE

Choose the operation performed when the shutter button is pressed during light trail photography.

Option	Description
SHUTTER OPEN WHEN PRESSING	The shutter opens while the shutter button is pressed.
SHUTTER CLOSED BY RE-PRESSING	The exposure starts when the shutter button is pressed and ends when the shutter button is pressed a second time.



SELF-TIMER

Use the timer for group- or self-portraits, to prevent blur caused by camera shake, or to release the shutter automatically when selected conditions are met (📖 85).

PHOTOMETRY

Choose how the camera meters exposure.



⚠ The selected option will only take effect when **AF/MF SETTING > FACE/EYE DETECTION SETTING** is **OFF**.

Mode	Description
 MULTI	The camera instantly determines exposure based on an analysis of composition, color, and brightness distribution. Recommended in most situations.
 SPOT	The camera meters lighting conditions in an area at the center of the frame equivalent to 2% of the total. Recommended with backlit subjects and in other cases in which the background is much brighter or darker than the main subject.
 AVERAGE	Exposure is set to the average for the entire frame. Provides consistent exposure across multiple shots with the same lighting, and is particularly effective for landscapes and portraits of subjects dressed in black or white.

SHUTTER TYPE

Choose the shutter type. Choose the electronic shutter to mute the shutter sound.





Option	Description
MS MECHANICAL SHUTTER	Take pictures with the mechanical shutter.
ES ELECTRONIC SHUTTER	Take pictures with the electronic shutter.
MS MECHANICAL + ES ELECTRONIC	The camera chooses the mechanical or electronic shutter according to shooting conditions.

-  When using the electronic shutter, note the following:
- Distortion may be visible in shots of moving subjects.
 - Distortion may also be visible in hand-held shots taken at high shutter speeds; use of a tripod is recommended.
 - Banding and fog may occur in shots taken under fluorescent lights or other flickering or erratic illumination.
 - When taking pictures with the shutter muted ( 161), respect your subjects' image rights and right to privacy.

-  The following restrictions apply when the electronic shutter is used:
- "Extended" sensitivities are not available
 - Long exposure noise reduction has no effect
 - The flash cannot be used

IS MODE

Choose from the following image stabilization options:

Option	Description
 CONTINUOUS + MOTION	Image stabilization on. If + MOTION is selected, the camera will adjust shutter speed to reduce motion blur when moving objects are detected.
 CONTINUOUS	
 SHOOTING + MOTION	As above, except that image stabilization is performed only when the shutter button is pressed halfway (focus mode  only) or the shutter is released. If + MOTION is selected, the camera will adjust shutter speed to reduce motion blur when moving objects are detected.
 SHOOTING ONLY	
OFF	Image stabilization off. Choose this option when using a tripod.

-  **+ MOTION** has no effect when sensitivity is set to a fixed value, and may also be unavailable at some other combinations of settings. The effect may vary with lighting conditions and the speed at which the object is moving.
- This option is available only with lenses that support image stabilization.

ISO

Adjust the camera's sensitivity to light.

Option	Description
AUTO1 AUTO2 AUTO3	Sensitivity is automatically adjusted in response to shooting conditions.
200–12800	
L (100) H (25600) H (51200)	Adjust sensitivity manually. Selected value is shown in display. Choose for special situations. Note that mottling may appear in pictures taken at H , while L reduces dynamic range.

-  Sensitivity is not reset when the camera is turned off.

Adjusting Sensitivity

High values can be used to reduce blur when lighting is poor, while lower values allow slower shutter speeds or wider apertures in bright light; note, however, that mottling may appear in pictures taken at high sensitivities.

AUTO

Choose the base sensitivity, maximum sensitivity, and minimum shutter speed for **AUTO1**, **AUTO2**, and **AUTO3**.

Item	Options	Default		
		AUTO1	AUTO2	AUTO3
DEFAULT SENSITIVITY	200–6400	200		
MAX. SENSITIVITY	400–6400	800	1600	3200
MIN. SHUTTER SPEED	$\frac{1}{500}$ – $\frac{1}{4}$ SEC, AUTO	AUTO		

The camera automatically chooses a sensitivity between the default and maximum values; sensitivity is only raised above the default value if the shutter speed required for optimal exposure would be slower than the value selected for **MIN. SHUTTER SPEED**.



- If the value selected for **DEFAULT SENSITIVITY** is higher than that selected for **MAX. SENSITIVITY**, **DEFAULT SENSITIVITY** will be set to the value selected for **MAX. SENSITIVITY**.
- The camera may select shutter speeds slower than **MIN. SHUTTER SPEED** if pictures would still be underexposed at the value selected for **MAX. SENSITIVITY**.
- If **AUTO** is selected for **MIN. SHUTTER SPEED**, the camera will automatically choose a minimum shutter speed approximately equal to the inverse of the lens' focal length, in seconds (for example, if the lens has a focal length of 50 mm, the camera will choose a minimum shutter speed in the neighborhood of $\frac{1}{50}$ s). The minimum shutter speed is not affected by the option selected for image stabilization.

MOUNT ADAPTOR SETTING

Adjust settings for M-mount lenses connected using an optional FUJIFILM M MOUNT ADAPTER.

Choosing a Focal Length

If the lens has a focal length of 21, 24, 28, or 35 mm, choose a matching option in the **MOUNT ADAPTOR SETTING** menu.

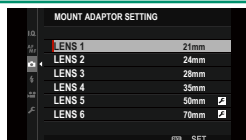

For other lenses, select option 5 or 6 to display the menu at right, press the selector right to display focal length settings, and use the selector to enter the focal length.

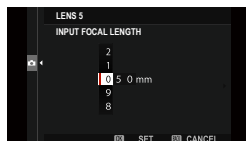

Distortion Correction

Choose from **STRONG**, **MEDIUM**, or **WEAK** options to correct **BARREL** or **PINCUSHION** distortion.

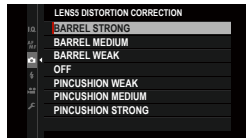

Color Shading Correction

Color (shading) variations between the center and edges of the frame can be adjusted separately for each corner.

To use color shading correction, follow the steps below.

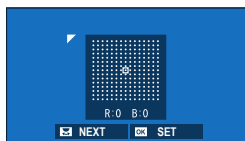



- 1 Rotate the rear command dial to choose a corner. The selected corner is indicated by a triangle.
- 2 Use the focus stick (focus lever) to adjust shading until there is no visible difference in color between the selected corner and the center of the image.
 - Press the focus stick left or right to adjust colors on the cyan–red axis.
 - Press the focus stick up or down to adjust colors on the blue–yellow axis.

 To determine the amount required, adjust color shading correction while taking photos of blue sky or a sheet of gray paper.

Peripheral Illumination Correction

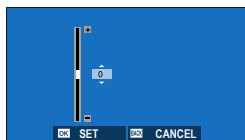
Choose from values between -5 and $+5$. Choosing positive values increases peripheral illumination, while choosing negative values reduces peripheral illumination. Positive values are recommended for vintage lenses, negative values to create the effect of images taken with an antique lens or a pinhole camera.



 To determine the amount required, adjust peripheral illumination correction while taking photos of blue sky or a sheet of gray paper.

TOUCH ZOOM

Enable touch digital zoom (📖 22).

Options	
ON	OFF

WIRELESS COMMUNICATION

Connect to smartphones running the latest version of the FUJIFILM Camera Remote app. The smartphone can then be used to:

- Control the camera and take pictures remotely
- Receive pictures uploaded from the camera
- Browse the pictures on the camera and download selected pictures
- Upload location data to the camera



For downloads and other information, visit:

http://app.fujifilm-dsc.com/en/camera_remote/



FLASH SETTING

Adjust flash-related settings.

To display flash-related settings, press **MENU/OK** in the shooting display and select the **⚡** (**FLASH SETTING**) tab.

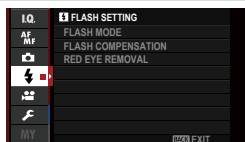

The options available vary with the shooting mode selected.

FLASH MODE

Choose a flash mode (94).

FLASH COMPENSATION

Adjust flash brightness. Choose from values between +2 EV and -2 EV.

Options

-2 | -1 2/3 | -1 1/3 | -1 | -2/3 | -1/3 | ±0 | +1/3 | +2/3 | +1 | +1 1/3 | +1 2/3 | +2



Note that the desired results may not be achieved depending on shooting conditions and the distance to the subject.

RED EYE REMOVAL

Choose **ON** to remove red-eye effects caused by the flash.

Options

ON

OFF



- Red-eye reduction is performed only when a face is detected.
- Red-eye removal is not available with RAW images.

MOVIE SETTING

Adjust movie-recording options.





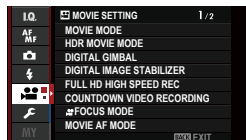























To display options for movie recording, press **MENU/OK** in the shooting display and select the  (**MOVIE SETTING**) tab.

 The options available vary with the shoot-
ing mode selected.



MOVIE MODE

Choose a frame size and rate for movie recording.

Option		Frame size	Rate
 29.97P ¹	 24P ¹	3840×2160 (4K)	29.97 fps, 25 fps, 24 fps, 23.98 fps
 25P ¹	 23.98P ¹		
 59.94P	 25P	1920×1080 (Full HD)	59.94 fps, 50 fps, 29.97 fps, 25 fps, 24 fps, 23.98 fps
 50P	 24P		
 29.97P	 23.98P		
 59.94P	 25P	1280×720 (HD)	59.94 fps, 50 fps, 29.97 fps, 25 fps, 24 fps, 23.98 fps
 50P	 24P		
 29.97P	 23.98P		
 59.94P	 25P	1080×1080 (Full HD)	59.94 fps, 50 fps, 29.97 fps, 25 fps, 24 fps, 23.98 fps
 50P	 24P		
 29.97P	 23.98P		
 59.94P	 25P	720×720 (HD)	59.94 fps, 50 fps, 29.97 fps, 25 fps, 24 fps, 23.98 fps
 50P	 24P		
 29.97P	 23.98P		

¹ Use a memory card with a UHS speed class of 3 or better when recording time-lapse movies that will be viewed on the camera.

HDR MOVIE MODE

Shoot movies with a high dynamic range.

Option	Description
1080/29.97P, 1080/25P, 1080/24P, 1080/23.98P	Film HDR movies at a frame size of 1920 × 1080 and a frame rate of 29.97, 25, 24, or 23.98 fps.
OFF	Disable HDR movie recording.

DIGITAL GIMBAL

Choose whether to enable a more powerful version of the **DIGITAL IMAGE STABILIZER**.

Options	
ON	OFF

-  Enabling the digital gimbal results in a smaller crop.
- The digital gimbal may be unavailable at certain combinations of settings or with some lenses.
- Zoom all the way out when using the digital gimbal with a zoom lens. If **ON** is selected for **DIGITAL GIMBAL**, power zoom lenses will automatically zoom all the way out as shooting begins.

DIGITAL IMAGE STABILIZER

Choose whether to enable digital image stabilization during movie recording.

Options	
ON	OFF

-  Select **OFF** if the camera is mounted on a tripod.

FULL HD HIGH SPEED REC

Record Full HD movies at a high frame rate. High-frame-rate movies can be played back in slow motion, giving you time to view fast-moving subjects or details too fleeting for the naked eye.

Option	Frame rate	Playback speed	Max. length
2x 59.94P 120P	120 fps	2x	Approx. 15 minutes
2x 50P 100P	100 fps		
4x 29.97P 120P	120 fps	4x	Approx. 7 minutes
4x 25P 100P	100 fps		
5x 24P 120P	120 fps	5x	Approx. 6 minutes
5x 23.98P 120P	120 fps		
OFF	Full HD high-speed recording off.		

- High-speed movies are compressed to approximately 46 Mbps when recorded to the memory card.
- High-speed movies are recorded with no sound.

COUNTDOWN VIDEO RECORDING

Choose the maximum movie recording time. A count-down timer is displayed during movie recording.

Options			
15 SEC	30 SEC	1 min.	OFF

FOCUS MODE

Choose the focus mode for movie recording.

Option	Description
MANUAL FOCUS	Focus manually.
CONTINUOUS AF	The camera focuses using AF-C.
SINGLE AF	The camera focuses using AF-S.

MOVIE AF MODE

Choose how the camera selects the focus point for movie recording.

Option	Description
 MULTI	Automatic focus-point selection.
 AREA	The camera focuses on the subject in the selected focus area.

ISO

Choose the sensitivity for movie recording.

Option	Description
AUTO	Sensitivity is automatically adjusted in response to shooting conditions.
400–6400	Adjust sensitivity manually. Selected value is shown in display.

 This setting has no effect on photographs.

HDMI OUTPUT INFO DISPLAY

If **ON** is selected, HDMI devices to which the camera is connected will mirror the information in the camera display.

Options	
ON	OFF

4K MOVIE OUTPUT

Choose the destination for 4K movies shot while the camera is connected to an HDMI recorder or other device that supports 4K.

Option	Description
 CARD	4K movies are recorded to a camera memory card and output to the HDMI device in 4K.
HDMI	4K movies are output to the HDMI device in 4K. The camera does not record 4K movies to a memory card.

HDMI REC CONTROL

Choose whether the camera sends movie start and stop signals to the HDMI device when the shutter or  (movie recording) button is pressed to start and stop movie recording.

Options	
ON	OFF

AUDIO SETTING

Adjust audio-related settings for movie recording.

INTERNAL MIC LEVEL ADJUSTMENT

Adjust the recording level for the built-in microphone.

Option	Description
AUTO	The camera adjusts the recording level automatically.
MANUAL	Adjust the recording level manually. Press the focus stick (focus lever) right to choose from 25 recording levels.
OFF	Turn the built-in microphone off.

EXTERNAL MIC LEVEL ADJUSTMENT

Adjust the recording level for external microphones.

Option	Description
AUTO	The camera adjusts the recording level automatically.
MANUAL	Adjust the recording level manually. Press the focus stick (focus lever) right to choose from 25 recording levels.
OFF	Disable recording using external microphones.

MIC LEVEL LIMITER

Reduces distortion caused by input that exceeds the limits of the microphone's audio circuits.

Options	
ON	OFF

WIND FILTER

Choose whether to enable wind noise reduction during movie recording.

Options	
ON	OFF

LOW CUT FILTER

Choose whether to enable the low-cut filter, reducing low-frequency noise during movie recording.

Options	
ON	OFF



HEADPHONES VOLUME

Adjust the headphone volume.

Option	Description
10—1	Choose a volume of from 1 to 10.
0	Mute output to the headphones.

MIC/REMOTE RELEASE

Specify whether the device connected to the microphone/remote release connector is a microphone or a remote release.

Options	
 MIC	 REMOTE

Playback and the Playback Menu

7

The Playback Display

This section lists the indicators that may be displayed during playback.

! For illustrative purposes, displays are shown with all indicators lit.

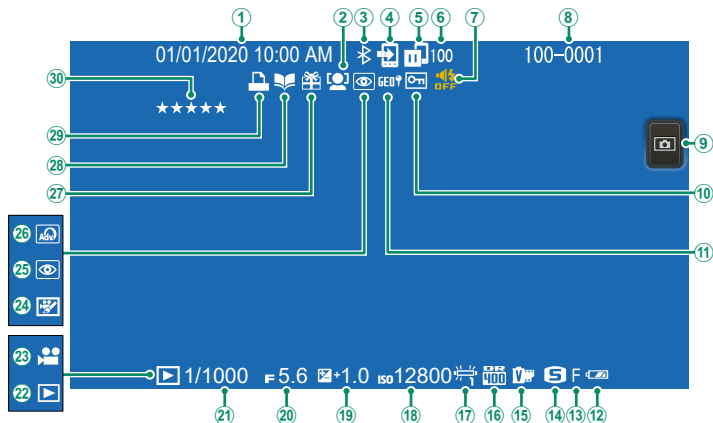

① Date and time.....	36, 157	⑩ Dynamic range	102
② Face detection indicator	107	⑪ White balance	81
③ Bluetooth ON/OFF.....	174	⑫ Sensitivity.....	118
④ Image transfer order.....	147, 174	⑬ Exposure compensation.....	79
⑤ Image transfer status.....	147, 174	⑭ Aperture.....	53, 56, 57
⑥ Number of frames selected for upload	147, 174	⑮ Shutter speed	53, 54, 57
⑦ Sound and flash indicator	158	⑯ Playback mode indicator	42
⑧ Frame number.....	172	⑰ Movie icon.....	49
⑨ Shooting mode.....	52	⑱ Movie trimming	143
⑩ Protected image.....	144	⑲ Red-eye removal indicator.....	146
⑪ Location data.....	175, 177	⑳ Advanced filter.....	66
⑫ Battery level.....	35	㉑ Gift image	42
⑬ Image quality.....	99	㉒ Photobook assist indicator	149
⑭ Image size.....	98	㉓ DPOF print indicator.....	151
⑮ Film simulation	100	㉔ Rating.....	133

The DISP/BACK Button

The **DISP/BACK** button controls the display of indicators during playback.

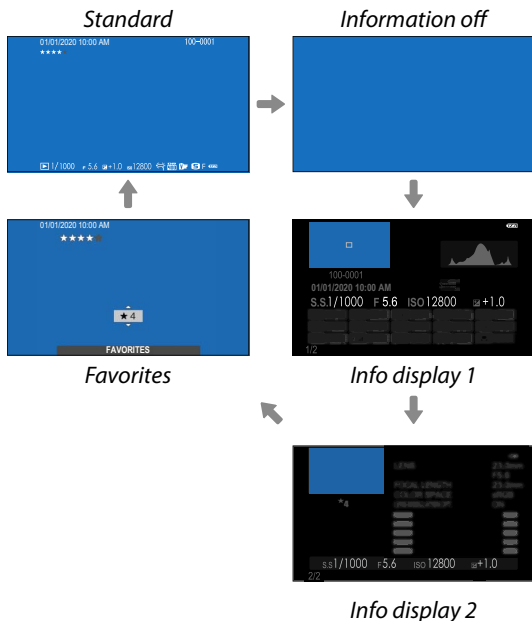
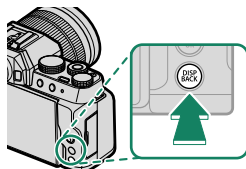

Favorites: Rating Pictures

To rate the current picture, press **DISP/BACK** and press the focus stick (focus lever) up and down to select from zero to five stars.

Zooming in on the Focus Point

Press the center of the focus stick (focus lever) to zoom in on the focus point. Press again to return to full-frame playback.

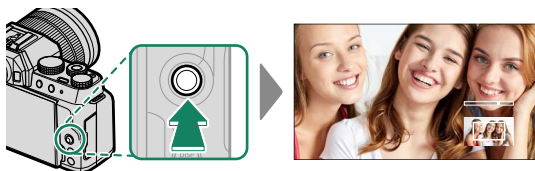

Viewing Pictures

Read this section for information on playback zoom and multi-frame playback.

Use the rear command dial to go from full-frame playback to playback zoom or multi-frame playback.

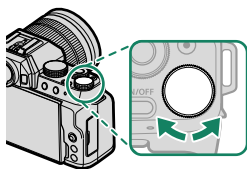

Full-frame playback



Multi-frame playback



Nine-frame view



Hundred-frame view

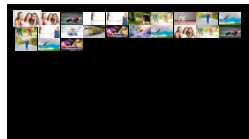

Playback zoom

**DISP/BACK
MENU/OK**



Medium zoom



Maximum zoom

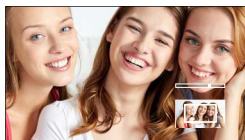

Playback Zoom

Rotate the rear command dial right to zoom in on the current picture, left to zoom out. To exit zoom, press **DISP/BACK** or **MENU/OK**.

- The maximum zoom ratio varies with the option selected for **IMAGE QUALITY SETTING > IMAGE SIZE**.
 - Playback zoom is not available with cropped or resized copies saved at a size of **640**.

Scroll

When the picture is zoomed in, the focus stick (focus lever) can be used to view areas of the image not currently visible in the display.



Navigation window

Multi-Frame Playback

To change the number of images displayed, rotate the rear command dial left when a picture is displayed full frame.

- Use the focus stick (focus lever) to highlight images and press **MENU/OK** to view the highlighted image full frame.
- In the nine- and hundred-frame displays, press the focus stick up or down to view more pictures.



The Playback Menu

Adjust playback settings.

The playback menu is displayed when you press **MENU/OK** in playback mode.

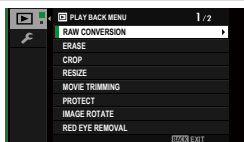

RAW CONVERSION

Even if you don't have a computer, you can use the camera to modify RAW pictures and save them in JPEG format.

Saving RAW Pictures in JPEG Format

- 1 Display a RAW picture.
- 2 Highlight **RAW CONVERSION** in the playback menu.
- 3 Press **MENU/OK**.
A list of settings will be displayed.

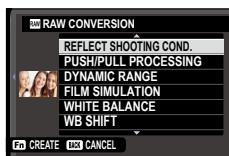

- 4 Press the focus stick (focus lever) up or down to highlight a setting.
- 5 Press the focus stick right to display options.

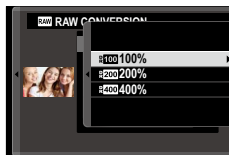

- 6 Press the focus stick up or down to highlight the desired option.

- 7 Press **MENU/OK** to select the highlighted option. The settings list shown in Step 3 will be displayed. Repeat Steps 4 to 7 to adjust additional settings.
- 8 Press the **Fn1** button.
A preview of the JPEG copy will be displayed.
- 9 Press **MENU/OK**.
The JPEG copy will be saved.



RAW conversion options can also be displayed by pressing the **Fn1** button when a RAW picture is displayed during playback.

The settings that can be adjusted when converting pictures from RAW to JPEG are:

Setting	Description
REFLECT SHOOTING COND.	Create a JPEG copy using the settings in effect at the time the photo was taken.
PUSH/PULL PROCESSING	Adjust exposure.
DYNAMIC RANGE	Enhance details in highlights for natural contrast.
FILM SIMULATION	Simulate the effects of different types of film.
WHITE BALANCE	Adjust white balance.
WB SHIFT	Fine-tune white balance.
HIGHLIGHT TONE	Adjust highlights.
SHADOW TONE	Adjust shadows.
COLOR	Adjust color density.
SHARPNESS	Sharpen or soften outlines.
NOISE REDUCTION	Process the copy to reduce mottling.
COLOR SPACE	Choose the color space used for color reproduction.

ERASE

Delete individual pictures, multiple selected pictures, or all pictures.

 Deleted pictures cannot be recovered. Protect important pictures or copy them to a computer or other storage device before proceeding.

Option	Description
FRAME	Delete pictures one at a time.
SELECTED FRAMES	Delete multiple selected pictures.
ALL FRAMES	Delete all unprotected pictures.

FRAME

- 1 Select **FRAME** for **ERASE** in the playback menu.
- 2 Press the focus stick (focus lever) left or right to scroll through pictures and press **MENU/OK** to delete.

 • A confirmation dialog is not displayed before pictures are deleted; be sure the correct picture is selected before pressing **MENU/OK**.

• Additional pictures can be deleted by pressing **MENU/OK**. Press the focus stick left or right to scroll through pictures and press **MENU/OK** to delete.

SELECTED FRAMES

- 1 Select **SELECTED FRAMES** for **ERASE** in the playback menu.
- 2 Highlight pictures and press **MENU/OK** to select.
 - Selected pictures are indicated by check marks (✓).
 - To deselect a highlighted picture, press **MENU/OK** again.
- 3 When the operation is complete, press **DISP/BACK** to display a confirmation dialog.
- 4 Highlight **OK** and press **MENU/OK** to delete the selected pictures.

 Pictures in photobooks or printer orders are shown by **!**.

ALL FRAMES

- 1 Select **ALL FRAMES** for **ERASE** in the playback menu.
- 2 A confirmation dialog will be displayed; highlight **OK** and press **MENU/OK** to delete all unprotected pictures.

 • Pressing **DISP/BACK** cancels deletion; note that any pictures deleted before the button was pressed cannot be recovered.

• If a message appears stating that the selected images are part of a DPOF print order, press **MENU/OK** to delete the pictures.

CROP

Create a cropped copy of the current picture.

- 1 Display the desired picture.
- 2 Select **CROP** in the playback menu.
- 3 Use the rear command dial to zoom in and out and press the focus stick (focus lever) up, down, left, or right to scroll the picture until the desired portion is displayed.
- 4 Press **MENU/OK** to display a confirmation dialog.
- 5 Press **MENU/OK** again to save the cropped copy to a separate file.



- The higher the zoom ratio, the smaller the number of pixels in the cropped copy.
- If the size of the final copy will be **640**, **YES** will be displayed in yellow.

RESIZE

Create a small copy of the current picture.

- 1 Display the desired picture.
- 2 Select **RESIZE** in the playback menu.
- 3 Highlight a size and press **MENU/OK** to display a confirmation dialog.
- 4 Press **MENU/OK** again to save the resized copy to a separate file.



The sizes available vary with the size of the original image.

MOVIE TRIMMING

Trim unwanted footage from movies. Trimmed copies are saved separately from the originals.

- 1 Select the movie you wish to edit.
- 2 Select **MOVIE TRIMMING** in the playback menu.
- 3 Pressing the focus stick (focus lever) down to start, pause, and resume playback, pause the movie on the first frame of the footage you intend to cut.

If the movie's first frame is included in the footage you intend to cut, skip this step and proceed directly to Step 4.

- 4 Press **MENU/OK** to select the current frame as the starting frame of the footage to be cut.
- 5 Pressing the focus stick down to resume and pause playback, pause the movie on the last frame of the footage you intend to cut.

If the movie's last frame is included in the footage you intend to cut, skip this step and proceed directly to Step 6.

- 6 Press **MENU/OK** to choose the end point and cut the selected footage from the movie.



- Do not turn the camera off until the process is complete.
- Footage cannot be trimmed from movies that are less than a second long.

PROTECT

Protect pictures from accidental deletion. Highlight one of the following options and press **MENU/OK**.

Option	Description
FRAME	Protect selected pictures. Press the focus stick (focus lever) left or right to view pictures and press MENU/OK to select or deselect. Press DISP/BACK when the operation is complete.
SET ALL	Protect all pictures.
RESET ALL	Remove protection from all pictures.



Protected pictures will be deleted when the memory card is formatted.



Protecting images currently selected for upload to paired smartphones or tablets removes upload marking.

IMAGE ROTATE

Rotate pictures.

- 1 Select **ON** for  **SCREEN SET-UP > AUTOROTATE PB.**
- 2 Display the desired picture.
- 3 Select **IMAGE ROTATE** in the playback menu.
- 4 Press the focus stick (focus lever) down to rotate the picture 90° clockwise, up to rotate it 90° counterclockwise.
- 5 Press **MENU/OK**. The picture will automatically be displayed in the selected orientation whenever it is played back on the camera.



- Protected pictures cannot be rotated. Remove protection before rotating pictures.
- The camera may not be able to rotate pictures created with other devices. Pictures rotated on the camera will not be rotated when viewed on a computer or on other cameras.
- Pictures taken with  **SCREEN SET-UP > AUTOROTATE PB** are automatically displayed in the correct orientation during playback.

RED EYE REMOVAL

Remove red-eye from portraits. The camera will analyze the image; if red-eye is detected, the image will be processed to create a copy with reduced red-eye.

- 1 Display the desired picture.
- 2 Select **RED EYE REMOVAL** in the playback menu.
- 3 Press **MENU/OK**.





- Results vary depending on the scene and the camera's success in detecting faces.
- The amount of time needed to process the image varies with the number of faces detected.
- Red eye cannot be removed from pictures that have already been processed using red-eye removal, which are indicated by a  icon during playback.
- Red eye removal cannot be performed on RAW images.

IMAGE TRANSFER ORDER

Select photos for upload to a paired smartphone or tablet.

- 1 Select **IMAGE TRANSFER ORDER > SELECT FRAMES** in the playback menu.
- 2 Highlight photos and press **MENU/OK** to select or deselect. Repeat until all the desired photos have been selected.
- 3 Press **DISP/BACK** to exit to playback.

 If **ON** is selected for **CONNECTION SETTING > Bluetooth SETTINGS > Bluetooth ON/OFF**, upload will begin shortly after you exit to playback or turn the camera off.

-  • Image transfer orders can contain a maximum of 999 pictures.
- The following cannot be selected for upload:
 - Protected pictures
 - Movies
 - RAW images
 - "Gift" pictures (pictures taken with other cameras)
 - If **PAIRING/TRANSFER ORDER** is selected for **CONNECTION SETTING > GENERAL SETTINGS > Wi-Fi BUTTON SETTING**, photos can also be marked for upload using the **Fn2** button.
 - To remove upload marking from all pictures in the current order, select **IMAGE TRANSFER ORDER > RESET ORDER**.
 - If **ON** is selected for **CONNECTION SETTING > Bluetooth SETTINGS > AUTO IMAGE TAGGING**, photos will automatically be marked for upload as they are taken.

WIRELESS COMMUNICATION

Connect to smartphones running the latest version of the FUJIFILM Camera Remote app. The smartphone can then be used to:

- Control the camera and take pictures remotely
- Receive pictures uploaded from the camera
- Browse the pictures on the camera and download selected pictures
- Upload location data to the camera



For downloads and other information, visit:

http://app.fujifilm-dsc.com/en/camera_remote/

SLIDE SHOW

View pictures in an automated slide show. Press **MENU/OK** to start and press the focus stick (focus lever) right or left to skip ahead or back. Press **DISP/BACK** at any time during the show to view on-screen help. The show can be ended at any time by pressing **MENU/OK**.



The camera will not turn off automatically while a slide show is in progress.

PHOTOBOOK ASSIST

Create books from your favorite photos.

Creating a Photobook

- 1 Select **NEW BOOK** for  **PLAY BACK MENU > PHOTOBOOK ASSIST**.
- 2 Scroll through the images and press the focus stick (focus lever) up to select or deselect. Press **MENU/OK** to exit when the book is complete.
- 3 Highlight **COMPLETE PHOTOBOOK** and press **MENU/OK** (to select all photos for the book, choose **SELECT ALL**). The new book will be added to the list in the photobook assist menu.



- Neither photographs **640** or smaller nor movies can be selected for photobooks.
- The first picture selected becomes the cover image. Press the focus stick down to select the current image for the cover instead.



- Books can contain up to 300 pictures.
- Books that contain no photos are automatically deleted.

Viewing Photobooks

Highlight a book in the photobook assist menu and press **MENU/OK** to display the book, then press the focus stick (focus lever) left or right to scroll through the pictures.

Editing and Deleting Photobooks

Display the photobook and press **MENU/OK**. The following options will be displayed; select the desired option and follow the on-screen instructions.

- **EDIT:** Edit the book as described in “Creating a Photobook”.
- **ERASE:** Delete the book.

PC AUTO SAVE

Upload pictures from the camera to a computer running the latest version of FUJIFILM PC AutoSave (note that you must first install the software and configure the computer as a destination for images copied from the camera).



For downloads and other information, visit:

http://app.fujifilm-dsc.com/en/pc_autosave/

PRINT ORDER (DPOF)

Create a digital “print order” for DPOF-compatible printers.

- 1 Select **PLAY BACK MENU > PRINT ORDER (DPOF)**.
- 2 Select **WITH DATE** to print the date of recording on pictures, **WITHOUT DATE** to print pictures without dates, or **RESET ALL** to remove all pictures from the print order before proceeding.
- 3 Display a picture you wish to include in or remove from the print order.
- 4 Press the focus stick (focus lever) up or down to choose the number of copies (up to 99).

To remove a picture from the order, press the focus stick down until the number of copies is 0.

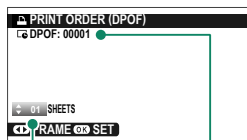

Total number of prints

Number of copies

Repeat steps 3–4 to complete the print order.

- 5 The total number of prints is displayed in the monitor. Press **MENU/OK** to exit.

- The pictures in the current print order are indicated by a  icon during playback.
- Print orders can contain a maximum of 999 pictures from a single memory card.
- If a memory card is inserted containing a print order created by another camera, you will need to delete the order before creating as described above.

instax PRINTER PRINT

To print pictures to optional Fujifilm instax SHARE printers, first select **CONNECTION SETTING > instax PRINTER CONNECTION SETTING** and enter the instax SHARE printer name (SSID) and password, then follow the steps below.

- 1 Turn the printer on.
- 2 Select **PLAY BACK MENU > instax PRINTER PRINT**. The camera will connect to the printer.
- 3 Use the focus stick (focus lever) to display the picture you want to print, then press **MENU/OK**. The picture will be sent to the printer and printing will start.



-  • Pictures taken with other cameras cannot be printed.
- The area printed is smaller than the area visible in the LCD monitor.
- The displays may vary depending on the printer connected.

DISP ASPECT

Choose the aspect ratio used for the display of still pictures on High Definition (HD) devices (this option is available only when an HDMI cable is connected).

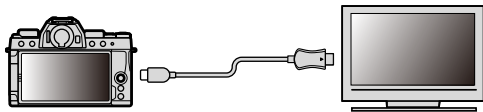
**Options****16:9****3:2**

-  Select **3:2** to display still pictures with aspect ratios other than **16:9** full screen with borders on either side.

The Setup Menus

8



USER SETTING

Adjust basic camera settings.

To access basic camera settings, press **MENU/OK**, select the **SET UP** tab, and choose **USER SETTING**.

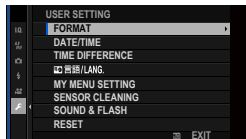

FORMAT

To format a memory card:

- 1 Select **USER SETTING** > **FORMAT** in the **SET UP** tab.
- 2 A confirmation dialog will be displayed. To format the memory card, highlight **OK** and press **MENU/OK**.



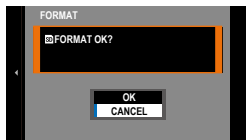

To exit without formatting the memory card, select **CANCEL** or press **DISP/BACK**.



- All data—including protected pictures—will be deleted from the memory card. Be sure important files have been copied to a computer or other storage device.
- Do not open the battery-chamber cover during formatting.

DATE/TIME



To set the camera clock:



- 1 Select  **USER SETTING** > **DATE/TIME** in the  (**SET UP**) tab.
- 2 Press the focus stick (focus lever) left or right to highlight the year, month, day, hour, or minute and press up or down to change. To change the order in which the year, month, and day are displayed, highlight the date format and press the focus stick up or down.
- 3 Press **MENU/OK** to set the clock.



TIME DIFFERENCE

Switch the camera clock instantly from your home time zone to the local time at your destination when traveling. To specify the difference between your local and home time zone:

- 1 Highlight  **LOCAL** and press **MENU/OK**.
- 2 Use the focus stick (focus lever) to choose the time difference between local time and your home time zone. Press **MENU/OK** when settings are complete.

To set the camera clock to local time, highlight  **LOCAL** and press **MENU/OK**. To set the clock to the time in your home time zone, select  **HOME**.

Options	
 LOCAL	 HOME

 If  **LOCAL** is selected,  will be displayed in yellow for about three seconds when the camera is turned on.

言語/LANG.

Choose a language.



MY MENU SETTING

Edit the items listed in the **MY** (MY MENU) tab, a personalized custom menu of frequently-used options ( 181).

SENSOR CLEANING

Remove dust from the camera image sensor.

Option	Description
OK	Clean the sensor immediately.
WHEN SWITCHED ON	Sensor cleaning will be performed when the camera is turned on.
WHEN SWITCHED OFF	Sensor cleaning will be performed when the camera turns off (sensor cleaning is not however performed if the camera turns off in playback mode).

 Dust that cannot be removed using sensor cleaning can be removed using a blower ( 228).

SOUND & FLASH

Select **OFF** to disable the speaker, flash, illuminator, and self-timer lamp in situations in which camera sounds and lights may be unwelcome.

Options	
ON	OFF

  appears in the display when **OFF** is selected.

RESET

Reset shooting or setup menu options to default values.

- 1 Highlight the desired option and press **MENU/OK**.

Option	Description
SHOOTING MENU RESET	Reset all shooting menu settings.
SET-UP RESET	Reset all setup menu settings other than DATE/TIME , TIME DIFFERENCE , and CONNECTION SETTING to default values.

- 2 A confirmation dialog will be displayed; highlight **OK** and press **MENU/OK**.

SOUND SETTING

Make changes to camera sounds.

To access sound settings, press **MENU/OK**, select the  (**SET UP**) tab, and choose **SOUND SET-UP**.

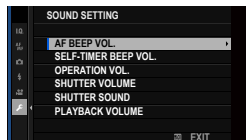

AF BEEP VOL.

Choose the volume of the beep that sounds when the camera focuses. The beep can be muted by selecting  **OFF**.

Options

 (high)

 (medium)

 (low)

 **OFF** (mute)

SELF-TIMER BEEP VOL.

Choose the volume of the beep that sounds while the self-timer is active. The beep can be muted by selecting  **OFF**.

Options

 (high)

 (medium)

 (low)

 **OFF** (mute)

OPERATION VOL.

Adjust the volume of the sounds produced when camera controls are operated. Choose  **OFF** to disable control sounds.

Options

 (high)

 (medium)

 (low)

 **OFF** (mute)



SHUTTER VOLUME

Adjust the volume of the sounds produced by the electronic shutter. Choose **OFF** to disable the shutter sound.

Options			
 (high)	 (medium)	 (low)	 OFF (mute)

SHUTTER SOUND

Choose the sound made by the electronic shutter.

Options		
 1 SOUND 1	 2 SOUND 2	 3 SOUND 3

PLAYBACK VOLUME

Adjust the volume for movie playback.

Options										
0	1	2	3	4	5	6	7	8	9	10

SCREEN SETTING

Make changes to display settings.

To access display settings, press **MENU/OK**, select the  (**SET UP**) tab, and choose **SCREEN SET-UP**.

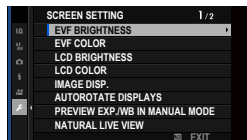

EVF BRIGHTNESS

Adjust the brightness of the display in the electronic viewfinder.

Option	Description
AUTO	Automatic brightness adjustment.
MANUAL	Adjust brightness manually; choose from options between -5 and +5.

EVF COLOR

Adjust the hue of the display in the electronic viewfinder.

Options											
-5	-4	-3	-2	-1	0	+1	+2	+3	+4	+5	

LCD BRIGHTNESS

Adjust monitor brightness.

Options											
-5	-4	-3	-2	-1	0	+1	+2	+3	+4	+5	

 Holding the **DISP/BACK** button during shooting sets **LCD BRIGHTNESS** to +5 and displays **LCD BRIGHTNESS** options.

LCD COLOR

Adjust monitor hue.

Options											
-5	-4	-3	-2	-1	0	+1	+2	+3	+4	+5	

IMAGE DISP.

Choose how long images are displayed after shooting.

Option	Description
CONTINUOUS	Pictures are displayed until the MENU/OK button is pressed or the shutter button is pressed halfway. To zoom in on the active focus point, press the center of the focus stick (focus lever); press again to cancel zoom.
1.5 SEC	Pictures are displayed for the selected time or until the shutter button is pressed halfway.
0.5 SEC	
OFF	Pictures are not displayed after shooting.



- Colors may differ slightly from those in the final image.
- “Noise” mottling may be visible at high sensitivities.

AUTOROTATE DISPLAYS

Choose whether the indicators in the viewfinder and LCD monitor rotate to match camera orientation.

Options	
ON	OFF

PREVIEW EXP./WB IN MANUAL MODE

Choose whether to enable exposure and/or white balance preview in manual exposure mode.

Option	Description
PREVIEW EXP./WB	Enable exposure and white balance preview.
PREVIEW WB	Preview white balance only. Choose this option in situations in which exposure and white balance are likely to change during shooting, as may be the case when you use a flash with an incandescent monitoring lamp.
OFF	Disable exposure and white balance preview. Choose this option when using a flash or on other occasions on which exposure may change when the picture is taken.



NATURAL LIVE VIEW

Choose whether the effects of film simulation, white balance, and other settings are visible in the monitor.

Option	Description
ON	The effects of camera settings are not visible in the monitor, but shadows in low-contrast, back-lit scenes and other hard-to-see subjects more visible. Colors and tone will differ from those in the final picture. The display will however be adjusted to show the effects of advanced filters and of monochrome and sepia settings.
OFF	The effects of film simulation, white balance, and other settings can be previewed in the monitor.

FRAMING GUIDELINE

Choose a framing grid for shooting mode.

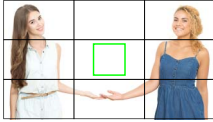
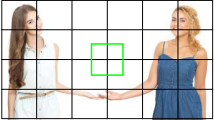
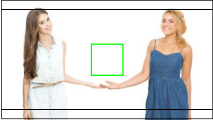
		Option		
		 GRID 9	 GRID 24	 HD FRAMING
Display				
		For "rule of thirds" composition.	A six-by-four grid.	Frame HD pictures in the crop shown by the lines at the top and bottom of the display.

 Framing guides are not shown at default settings but can be displayed using  **SCREEN SET-UP** > **DISP. CUSTOM SETTING** ( 16).

AUTOROTATE PB

Choose **ON** to automatically rotate “tall” (portrait-orientation) pictures during playback.

Options	
ON	OFF

FOCUS SCALE UNITS

Choose the units used for the focus distance indicator.

Options	
METERS	FEET

DISP. CUSTOM SETTING

Choose the items shown in the standard indicator display (📖 16).

LARGE INDICATORS MODE(EVF)

Select **ON** to display large indicators in the electronic viewfinder. The indicators displayed can be selected using **SCREEN SET-UP > LARGE INDICATORS DISP. SETTING**.



OFF

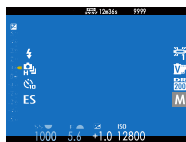

ON

Some icons are not displayed when **ON** is selected for **LARGE INDICATORS MODE(EVF)** (10).

If **LARGE INDICATORS MODE** is assigned to a function button, the button can be used to toggle **LARGE INDICATORS MODE** on (**ON**) and off (**OFF**) (186).

LARGE INDICATORS MODE(LCD)

Select **ON** to display large indicators in the LCD monitor. The indicators displayed can be selected using **SCREEN SET-UP > LARGE INDICATORS DISP. SETTING**.



OFF



ON

Some icons are not displayed when **ON** is selected for **LARGE INDICATORS MODE(LCD)** (10).

If **LARGE INDICATORS MODE** is assigned to a function button, the button can be used to toggle **LARGE INDICATORS MODE** on (**ON**) and off (**OFF**) (186).

LARGE INDICATORS DISP. SETTING

Choose the indicators displayed when **ON** is selected for **SCREEN SET-UP > LARGE INDICATORS MODE(EVF)** or **LARGE INDICATORS MODE(LCD)**.



Option	Description
① Expo. DISP.	Choose the items listed at the bottom of the display. Selected items are indicated by check marks (☑); to deselect, highlight the check marks and press MENU/OK .
② Scale	Select ON to display the exposure indicator.
③ L1, L2, L3, L4	Choose up to four large icons for display on the left side of the screen.
④ R1, R2, R3, R4	Choose up to four large icons for display on the right side of the screen.

BUTTON/DIAL SETTING

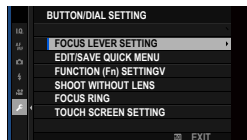

Access options for camera controls.

To access control options, press **MENU/OK**, select the  (**SET UP**) tab, and choose **BUTTON/DIAL SETTING**.



FOCUS LEVER SETTING

Choose the functions performed by the focus stick (focus lever).

Option	Description
LOCK (OFF)	The focus stick cannot be used during shooting.
ZOOM INTO THE FOCUS BY PRESSING  FOCUS STICK	Press the focus stick to zoom in on the view through the lens for more accurate focus.
PUSH  TO UNLOCK	Press the stick to view the focus-point display and tilt the stick to select a focus point.
ON	Tilt the stick to view the focus-point display and select a focus point.

 **FOCUS LEVER SETTING** options can also be accessed by pressing and holding the focus stick.

EDIT/SAVE QUICK MENU

Choose the items displayed in the quick menu (📖 185).

FUNCTION (Fn) SETTING

Choose the roles played by the function (**Fn1** and **Fn2**) buttons, the **Fn** (function) dial, and the touch function (**T.B. Fn1** and **T.B. Fn2**) buttons (📖 186).



SHOOT WITHOUT LENS

Choose **ON** to enable the shutter release when no lens is attached.

Options	
ON	OFF



FOCUS RING

Choose the direction in which the focus ring is rotated to increase the focus distance.

Options	
 CW (clockwise)	 CCW (counterclockwise)

TOUCH SCREEN SETTING

Enable or disable touch-screen controls.

Option	Description								
 TOUCH SCREEN SETTING	<ul style="list-style-type: none"> • ON: The LCD monitor functions as a touch screen during shooting. • OFF: Touch controls disabled. 								
 DOUBLE TAP SETTING	<ul style="list-style-type: none"> • ON: Tap the LCD monitor twice to zoom in on your subject during shooting. • OFF: Touch zoom disabled. 								
 TOUCH SCREEN SETTING	<ul style="list-style-type: none"> • ON: The LCD monitor functions as a touch screen during playback. • OFF: Touch controls disabled. 								
TOUCH SCREEN MENU SETTING	<ul style="list-style-type: none"> • ON: The LCD monitor functions as a touch screen when menus are displayed. • OFF: Touch controls disabled. 								
SELFIE MODE TOUCH PLAYBACK BUTTON	<ul style="list-style-type: none"> • ON: A playback button appears in the touch menu in self-portrait mode. • OFF: A playback button is not displayed in the touch menu in self-portrait mode. 								
EVF TOUCH SCREEN AREA SETTINGS	<p>Select the area of the LCD monitor used for touch controls while the viewfinder is active.</p> <ul style="list-style-type: none"> • The area used for touch controls can be selected from: <table border="0" style="width: 100%;"> <tr> <td>- <input type="checkbox"/> (all)</td> <td>- <input type="checkbox"/> (left half)</td> </tr> <tr> <td>- <input type="checkbox"/> (right half)</td> <td>- <input type="checkbox"/> (top left quarter)</td> </tr> <tr> <td>- <input type="checkbox"/> (top right quarter)</td> <td>- <input type="checkbox"/> (bottom left quarter)</td> </tr> <tr> <td>- <input type="checkbox"/> (bottom right quarter)</td> <td></td> </tr> </table> • Choose OFF to disable touch controls while the viewfinder is active. 	- <input type="checkbox"/> (all)	- <input type="checkbox"/> (left half)	- <input type="checkbox"/> (right half)	- <input type="checkbox"/> (top left quarter)	- <input type="checkbox"/> (top right quarter)	- <input type="checkbox"/> (bottom left quarter)	- <input type="checkbox"/> (bottom right quarter)	
- <input type="checkbox"/> (all)	- <input type="checkbox"/> (left half)								
- <input type="checkbox"/> (right half)	- <input type="checkbox"/> (top left quarter)								
- <input type="checkbox"/> (top right quarter)	- <input type="checkbox"/> (bottom left quarter)								
- <input type="checkbox"/> (bottom right quarter)									



POWER MANAGEMENT

Adjust power management settings.

To access power management settings, press **MENU/OK**, select the **SET UP** tab, and choose **POWER MANAGEMENT**.

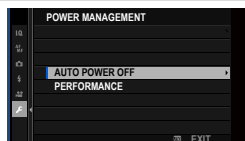

AUTO POWER OFF

Choose the length of time before the camera turns off automatically when no operations are performed. Shorter times increase battery life; if **OFF** is selected, the camera must be turned off manually.

Options		
5 MIN	2 MIN	OFF

PERFORMANCE

Adjust power settings.

Option	Startup	Frame rate	Battery endurance
HIGH PERFORMANCE	Fast	Fast	Low
STANDARD	Normal	Fast	Normal
ECONOMY	Normal	Low	Hight

SAVE DATA SETTING

Make changes to file management settings.

To access file management settings, press **MENU/OK**, select the  (**SET UP**) tab, and choose **SAVE DATA SET-UP**.

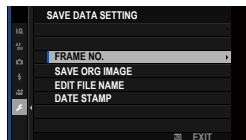

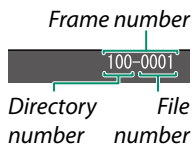

FRAME NO.

New pictures are stored in image files named using a four-digit file number assigned by adding one to the last file number used. The file number is displayed during playback as shown. **FRAME NO.** controls whether file numbering is reset to 0001 when a new memory card is inserted or the current memory card is formatted.



Option	Description
CONTINUOUS	Numbering continues from the last file number used or the first available file number, whichever is higher. Choose this option to reduce the number of pictures with duplicate file names.
RENEW	Numbering is reset to 0001 after formatting or when a new memory card is inserted.

-  If the frame number reaches 999-9999, the shutter release will be disabled. Format the memory card after transferring to a computer any pictures you wish to keep.
- Selecting  **USER SETTING** > **RESET** sets **FRAME NO.** to **CONTINUOUS** but does not reset the file number.
- Frame numbers for pictures taken with other cameras may differ.

SAVE ORG IMAGE

Choose **ON** to save unprocessed copies of pictures taken using **RED EYE REMOVAL**.

Options	
ON	OFF



EDIT FILE NAME

Change the file name prefix. sRGB images use a four-letter prefix (default "DSCF"), Adobe RGB images a three-letter prefix ("DSF") preceded by an underscore.

Option	Default prefix	Sample file name
sRGB	DSCF	ABCD0001
AdobeRGB	_DSF	_ABC0001

DATE STAMP

Stamp the time and/or date of recording on photographs as they are taken.

Option	Description
 DATE & TIME	Stamp new photographs with the date and time of recording.
 DATE	Stamp new photographs with the date of recording.
OFF	Do not stamp the time and date on new photographs.

-  Time and date stamps cannot be deleted. Turn **DATE STAMP** off to prevent time and date stamps appearing on new photographs.
- If the camera clock is not set, you will be prompted to set the clock to the current date and time (📖 36, 38).
- We recommend that you turn the DPOF "print date" option off when printing images with a time and date stamp (📖 151).
- Time and date stamps do not appear on movies or RAW images.

CONNECTION SETTING

Adjust settings for connection to other devices.

To access connection settings, press **MENU/OK**, select the **SET UP** tab, and choose **CONNECTION SETTING**.

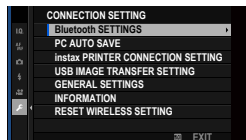

For more information on wireless connections, visit:
<http://fujifilm-dsc.com/wifi/>

Bluetooth SETTINGS

Adjust Bluetooth settings.

Option	Description
PAIRING REGISTRATION	Pair the camera with a smartphone to which the FUJIFILM Camera Remote app has been installed.
SELECT PAIRING DESTINATION	Choose a connection from a list of devices with which the camera has been paired using PAIRING REGISTRATION . Select NO CONNECTION to exit without connecting.
DELETE PAIRING REG.	Delete pairing information for selected devices. Choose the device in the device list. The selected device will also be removed from the devices listed in SELECT PAIRING DESTINATION .
Bluetooth ON/OFF	<ul style="list-style-type: none">• ON: The camera automatically establishes a Bluetooth connection with paired devices when turned on.• OFF: The camera does not connect via Bluetooth.
AUTO IMAGE TAGGING	<ul style="list-style-type: none">• ON: Mark JPEG images for upload as they are taken.• OFF: Photos are not marked for upload as they are taken.
SEAMLESS TRANSFER	<ul style="list-style-type: none">• ON: Pictures are uploaded to paired devices after shooting.• OFF: Pictures are uploaded to paired devices only when the camera is off or starting shortly after you exit to playback.

Option	Description
SMARTPHONE SYNC. SETTING	<p>Choose whether to synchronize the camera to the time and/or location provided by a paired smartphone.</p> <ul style="list-style-type: none"> • LOCATION&TIME: Synchronize the time and location. • LOCATION: Synchronize the location. • TIME: Synchronize the time. • OFF: Synchronization off.

- Install the latest version of the FUJIFILM Camera Remote app on your smartphone or tablet before pairing the device with your camera or uploading images.
- When **ON** is selected for both **Bluetooth ON/OFF** and **AUTO IMAGE TAGGING** and **OFF** is chosen for **SEAMLESS TRANSFER**, upload to paired devices will begin when the camera is turned off or shortly after you exit to playback.
- If **AUTO IMAGE TAGGING** is off, pictures can be marked for transfer using the **IMAGE TRANSFER ORDER** option in the playback menu.

PC AUTO SAVE

Adjust settings for connection to computers via wireless LAN.

Option	Description
PC AUTO SAVE SETTING	<p>Choose the method used for connection to computers via a wireless LAN.</p> <ul style="list-style-type: none"> • SIMPLE SETUP: Connect using WPS. • MANUAL SETUP: Choose the network from a list (SELECT FROM NETWORK LIST) or enter the name manually (ENTER SSID).
DELETE REGISTERED DESTINATION PC	Remove selected destinations.
DETAILS OF PREVIOUS CONNECTION	View computers to which the camera has recently connected.

instax PRINTER CONNECTION SETTING

Adjust settings for connection to optional Fujifilm instax SHARE printers.

The Printer Name (SSID) and Password

The printer name (SSID) can be found on the bottom of the printer; the default password is "1111". If you have already chosen a different password to print from a smartphone, enter that password instead.

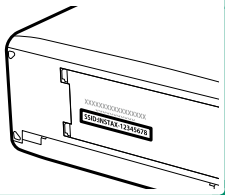





USB IMAGE TRANSFER SETTING

Choose whether to pictures can be copied to computers or smartphones connected to the camera via USB.



GENERAL SETTINGS

Adjust settings for connection to wireless networks.

Option	Description
NAME	Choose a name (NAME) to identify the camera on the wireless network (the camera is assigned a unique name by default).
RESIZE IMAGE FOR SMARTPHONE 	Choose whether to resize images for upload to smartphones. Resizing applies only to the copy uploaded to the smartphone; the original is not affected. <ul style="list-style-type: none"> • ON: Larger images are resized to  for upload. • OFF: Images are uploaded at their original size.
GEOTAGGING	Choose whether location data downloaded from a smartphone are embedded in pictures as they are taken.
LOCATION INFO	Display the location data last downloaded from a smartphone.
 BUTTON SETTING	Choose the role played by function buttons assigned the WIRELESS COMMUNICATION function. <ul style="list-style-type: none"> •  PAIRING/TRANSFER ORDER: The buttons can be used for pairing and selecting images for transfer. •  WIRELESS COMMUNICATION: The buttons can be used for wireless connections.

INFORMATION

View the camera's MAC and Bluetooth address.

RESET WIRELESS SETTING

Restore wireless settings to their default values.

Shortcuts

9

Shortcut Options

Customize camera controls to suit your style or situation.

Frequently-used options can be added to “my menu” or the **Q** menu or assigned to the function (**Fn1** and **Fn2**) buttons, the **Fn** (function) dial, or the touch function (**T.B. Fn1** and **T.B. Fn2**) buttons for direct access:

- **My menu** (📖 181): Add frequently-used options to this custom menu, which can be viewed by pressing **MENU/OK** and selecting the **M** (“MY MENU”) tab.
- **The Q menu** (📖 183): The **Q** menu is displayed by pressing the **Q** button. Use the **Q** menu to view or change the options selected for frequently-used menu items.
- **The function button** (📖 186): Use the function (**Fn1/Fn2**) button for direct access to selected features.
- **The function dial** (📖 188): Rotate the **Fn** (function) dial for direct access to selected features.
- **Touch function buttons** (📖 189): Use the touch function buttons (**T.B. Fn1/T.B. Fn2**) in the touch menu for direct access to selected features.



MY MENU

Access a personalized menu of frequently-used options.

To display “my menu”, press **MENU/OK** in the shooting display and select the **MY** (**MY MENU**) tab.

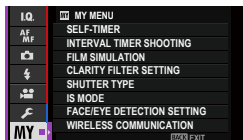

The **MY** tab is only available if options have been assigned to **MY MENU**.

MY MENU SETTING

To choose the items listed in the **MY** (**MY MENU**) tab:

- 1 Highlight **USER SETTING > MY MENU SETTING** in the **(SET UP)** tab and press **MENU/OK**.

To reorder items, select **RANK ITEMS**.
To delete items, select **REMOVE ITEMS**.

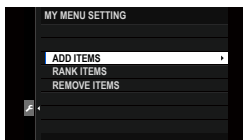

- 2 Press the focus stick (focus lever) up or down to highlight **ADD ITEMS** and press **MENU/OK**. Options that can be added to “my menu” are highlighted in blue.

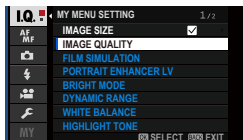

Items currently in “my menu” are indicated by check marks.

- 3 Choose a position for the item and press **MENU/OK**. The item will be added to “my menu”.



- 4 Press **MENU/OK** to return to the edit display.
- 5 Repeat Steps 3 and 4 until all the desired items have been added.

 “My menu” can contain up to 16 items.

The Quick Menu

Use the quick menu for quick access to selected options.

The Quick Menu Display

At default settings, the quick menu contains the following items:

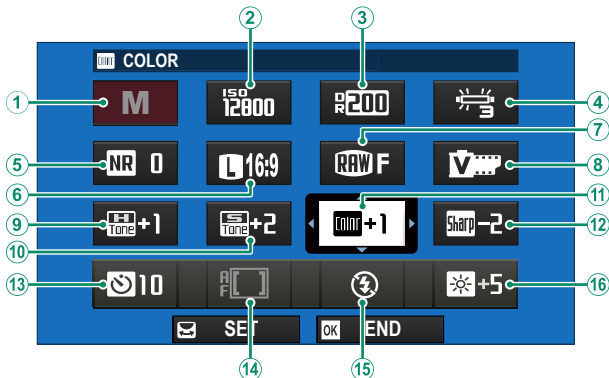

- ① SHOOTING MODE
- ② ISO
- ③ DYNAMIC RANGE
- ④ WHITE BALANCE
- ⑤ NOISE REDUCTION
- ⑥ IMAGE SIZE
- ⑦ IMAGE QUALITY
- ⑧ FILM SIMULATION

- ⑨ HIGHLIGHT TONE
- ⑩ SHADOW TONE
- ⑪ COLOR
- ⑫ SHARPNESS
- ⑬ SELF-TIMER
- ⑭ AF MODE
- ⑮ FLASH MODE
- ⑯ EVF/LCD BRIGHTNESS

Viewing and Changing Settings

- 1 Tap the **Q** button in the touch menu.
The quick menu will be displayed.



- 2 Use the focus stick (focus lever) to highlight items.



- 3 Rotate the rear/front command dial to make changes to the highlighted item.

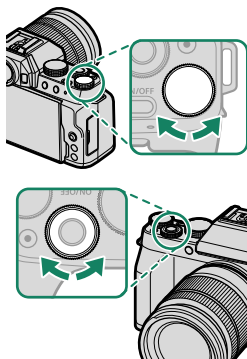

- 4 Press the focus stick or **MENU/OK** to save changes and exit to the shooting display when settings are complete.

- The shooting mode is the current shooting mode and cannot be changed from the quick menu.
- **CUSTOM** and **COLOR TEMPERATURE** white balance options cannot be accessed via the quick menu. Use a function button or the shooting menu.

Editing the Quick Menu

The following items can be assigned to the quick menu using the **■** **BUTTON/DIAL SETTING > EDIT/SAVE QUICK MENU** option in the setup menu.

- IMAGE SIZE
- IMAGE QUALITY
- FILM SIMULATION
- DYNAMIC RANGE
- WHITE BALANCE
- HIGHLIGHT TONE
- SHADOW TONE
- COLOR
- SHARPNESS
- NOISE REDUCTION
- FOCUS MODE
- AF MODE
- FACE/EYE DETECTION SETTING
- MF ASSIST
- TOUCH SCREEN MODE
- SELF-TIMER
- PHOTOMETRY
- SHUTTER TYPE
- IS MODE
- ISO
- FLASH MODE
- FLASH COMPENSATION
- MOVIE MODE
- FULL HD HIGH SPEED REC
- HDR MOVIE MODE
- FOCUS MODE
- MOVIE AF MODE
- DIGITAL IMAGE STABILIZER
- DIGITAL GIMBAL
- MOVIE ISO
- INTERNAL/EXTERNAL MIC LEVEL ADJUSTMENT
- SOUND & FLASH
- EVF/LCD BRIGHTNESS
- EVF/LCD COLOR
- NONE



Select **NONE** to assign no option to the selected position.

Function Controls

Each of the function (**Fn1** and **Fn2**) buttons, the **Fn** (function) dial, and touch function (**T.B. Fn1** and **T.B. Fn2**) buttons can be assigned its own role.

The Function Buttons

Assign roles to the function (**Fn1** and **Fn2**) buttons for quick access.

Function Button Defaults

The default assignments are:

Fn1 button

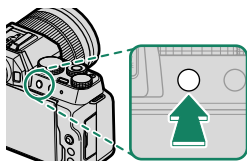

TOUCH MENU

Fn2 button

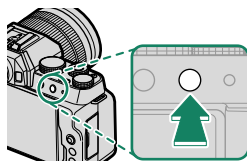

AE-LOCK

Assigning Roles to the Function Buttons

The roles played by the function (**Fn1** and **Fn2**) buttons can be selected using the **FUNCTION/DIAL SETTING > FUNCTION (Fn) SETTING** option in the setup menu.

- IMAGE SIZE
- IMAGE ASPECT
- IMAGE QUALITY
- RAW
- FILM SIMULATION
- DYNAMIC RANGE
- WHITE BALANCE
- FOCUS AREA
- FOCUS CHECK
- FOCUS MODE
- AF MODE
- FACE/EYE DETECTION SETTING
- TOUCHZOOM
- SELF-TIMER
- AE BKT SETTING
- PHOTOMETRY
- SHUTTER TYPE
- ISO
- IS MODE
- WIRELESS COMMUNICATION
- FLASH MODE
- FLASH COMPENSATION
- MOVIE RECORDING RELEASE
- MOVIE MODE
- FULL HD HIGH SPEED REC
- COUNTDOWN VIDEO RECORDING
- HDR MOVIE MODE
- FOCUS MODE
- MOVIE AF MODE
- DIGITAL IMAGE STABILIZER
- DIGITAL GIMBAL
- MOVIE ISO
- INTERNAL/EXTERNAL MIC LEVEL ADJUSTMENT
- PREVIEW EXP./WB IN MANUAL MODE
- NATURAL LIVE VIEW
- LARGE INDICATORS MODE
- AE-LOCK
- AF-LOCK
- AE/AF LOCK
- AUTO IMAGE TAGGING
- SELECT PAIRING DESTINATION
- Bluetooth ON/OFF
- QUICK MENU
- TOUCH MENU
- NONE



 To disable the function button, choose **NONE**.

The Function Dial

The role played by the function dial can be selected using

 **BUTTON/DIAL SETTING > FUNCTION (Fn) SETTING.**

- EXPOSURE COMPENSATION
- IMAGE SIZE
- IMAGE ASPECT
- IMAGE QUALITY
- FILM SIMULATION
- DYNAMIC RANGE
- WHITE BALANCE
- FOCUS MODE
- AF MODE
- FACE/EYE DETECTION SETTING
- SELF-TIMER
- PHOTOMETRY
- SHUTTER TYPE
- ISO
- IS MODE
- FLASH MODE
- FLASH COMPENSATION
- MOVIE MODE
- FULL HD HIGH SPEED REC
- COUNTDOWN VIDEO RECORDING
- HDR MOVIE MODE
- FOCUS MODE
- MOVIE AF MODE
- MOVIE ISO
- DEFAULT
- NONE

-  • To disable the function dial, select **NONE**.
- Note, however, that function dial can still be used when **NONE** is selected to adjust shutter speed in  (**MOVIE**) mode.
- If **DEFAULT** is selected, the role played by the function dial will be tailored to the mode currently chosen with the mode dial ( 7).

Touch Function Buttons

Assign roles to the touch function buttons (**T.B. Fn1/T.B. Fn2**) for quick access to the selected functions.

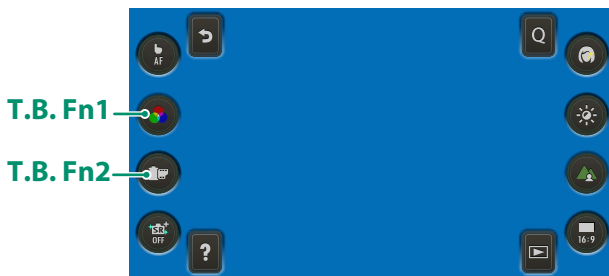

The role played by the **T.B. Fn1** and **T.B. Fn2** buttons can be selected using the **FUNCTION/DIAL SETTING > FUNCTION (Fn) SETTING** option in the setup menu.

- IMAGE SIZE
- IMAGE ASPECT
- IMAGE QUALITY
- RAW
- FILM SIMULATION
- DYNAMIC RANGE
- WHITE BALANCE
- FOCUS AREA
- FOCUS CHECK
- FOCUS MODE
- AF MODE
- FACE/EYE DETECTION SETTING
- TOUCHZOOM
- SELF-TIMER
- AE BKT SETTING
- PHOTOMETRY
- SHUTTER TYPE
- ISO
- IS MODE
- WIRELESS COMMUNICATION
- FLASH MODE
- FLASH COMPENSATION
- MOVIE MODE
- FULL HD HIGH SPEED REC
- COUNTDOWN VIDEO RECORDING
- HDR MOVIE MODE
- FOCUS MODE
- MOVIE AF MODE
- DIGITAL IMAGE STABILIZER
- DIGITAL GIMBAL
- MOVIE ISO
- INTERNAL/EXTERNAL MIC LEVEL ADJUSTMENT
- PREVIEW EXP/WB IN MANUAL MODE
- NATURAL LIVE VIEW
- LARGE INDICATORS MODE
- AUTO IMAGE TAGGING
- SELECT PAIRING DESTINATION
- Bluetooth ON/OFF
- NONE



- To disable the touch function buttons, choose **NONE**.
- The default assignments for the touch menu **T.B. Fn1** and **T.B. Fn2** buttons are respectively **WHITE BALANCE** and **FILM SIMULATION**.

10 Peripherals and Optional Accessories

Lenses

The camera can be used with lenses for the FUJIFILM X-mount.

Lens Parts

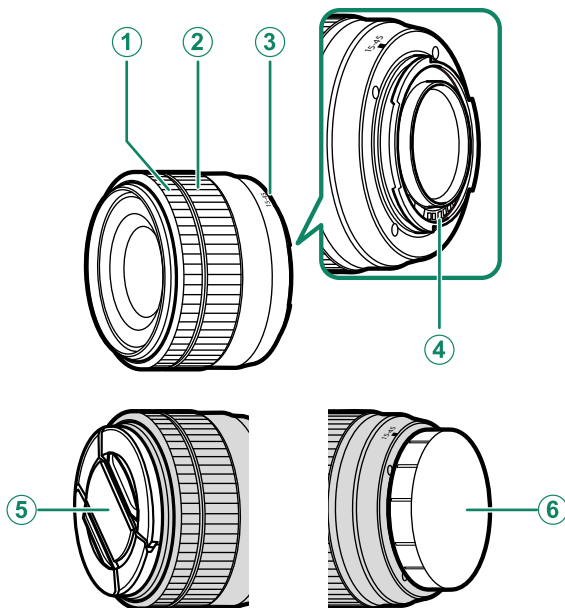

- ① Focus ring
- ② Zoom ring
- ③ Mounting marks

- ④ Lens signal contacts
- ⑤ Front lens cap
- ⑥ Rear lens cap

 A XC15-45mmF3.5-5.6 OIS PZ is used here for illustrative purposes.

Power Zoom

The focus ring can be used to adjust zoom when autofocus is enabled.

Removing Lens Caps

Remove lens caps as shown.

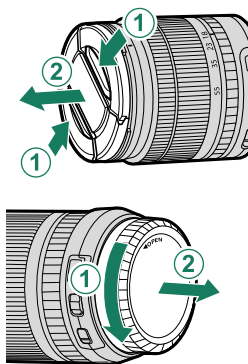

 Lens caps may differ from those shown.

Lenses with Lens Hoods

When attached, lens hoods reduce glare and protect the front lens element.

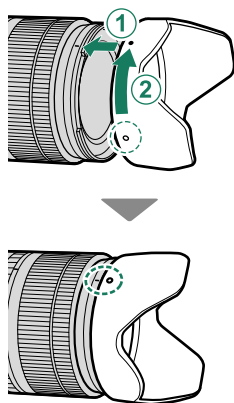

Lenses with Aperture Rings

At settings other than **A**, you can adjust aperture by rotating the lens aperture ring (exposure modes **A** and **M**).

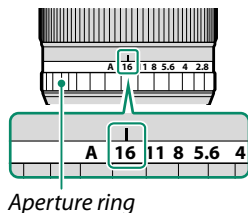

Aperture ring

The Aperture Mode Switch

If the lens has an aperture mode switch, aperture can be adjusted manually by sliding the switch to  and rotating the aperture ring.

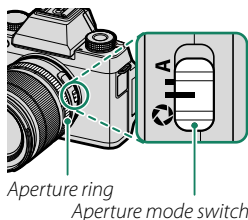

Aperture ring

Aperture mode switch

 When the aperture ring is set to **A**, aperture can be adjusted by rotating the front command dial.

Lenses with O.I.S. Switches

If the lens supports optical image stabilization (O.I.S.), the image stabilization mode can be chosen in the camera menus. To activate image stabilization, slide the O.I.S. switch to **ON**.

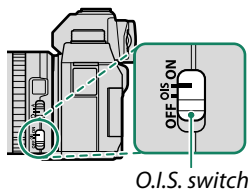

Manual Focus Lenses

Slide the focus ring to the front for autofocus.

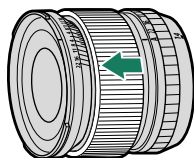

For manual focus, slide the focus ring to the back and rotate it while checking the results in the camera display. The focus distance and depth-of-field indicators can be used to assist manual focus.

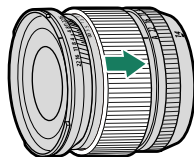

! Note that manual focus may not be available in all shooting modes.

The Depth-of-Field Indicator

The depth-of-field indicator shows the approximate depth of field (the distance in front of and behind the focus point that appears to be in focus). The indicator is displayed in film format.

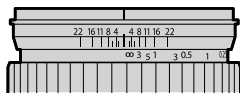

Lens Care

- Use a blower to remove dust, then gently wipe with a soft, dry cloth. Any remaining stains can be removed by wiping gently with a piece of Fujifilm lens-cleaning paper to which a small amount of lens-cleaning fluid has been applied.
- Replace the front and rear caps when the lens is not in use.

11 Connections

HDMI Output

Camera shooting and playback displays can be output to HDMI devices.

Connecting to HDMI Devices

Connect the camera to TVs or other HDMI devices using a third-party HDMI cable.

- 1 Turn the camera off.
- 2 Connect the cable as shown below, making sure the connectors are fully inserted.

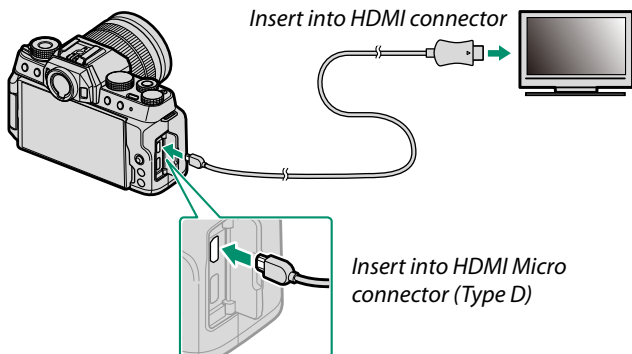

- 3 Configure the device for HDMI input as described in the documentation supplied with the device.
- 4 Turn the camera on. The contents of the camera display will be shown on the HDMI device. The camera display turns off in playback mode (📖 199).

- ! • Making sure the connectors are fully inserted.
- Use an HDMI cable no more than 1.5 m (4.9 ft.) long.

Shooting

Shoot photos and record movies while viewing the scene through the camera lens or saving footage to the HDMI device.

 This feature can be used to save 4K and Full HD movies to an HDMI recorder.

Playback

To start playback, press the camera  button. The camera monitor turns off and pictures and movies are output to the HDMI device. Note that the camera volume controls have no effect on sounds played on the TV; use the television volume controls to adjust the volume.

 Some televisions may briefly display a black screen when movie playback begins.

Wireless Connections (Bluetooth®, Wireless LAN/Wi-Fi)

Access wireless networks and connect to computers, smartphones, or tablets. For more information, visit:

<http://fujifilm-dsc.com/wifi/>

Smartphones and Tablets: FUJIFILM Camera Remote

Connect to the camera via Bluetooth or wireless LAN.

 To establish a wireless connection to the camera, you will need to install the latest version of the FUJIFILM Camera Remote app on your smartphone or tablet.

FUJIFILM Camera Remote

Once a connection has been established, you can use FUJIFILM Camera Remote to:

- Control the camera and take pictures remotely
- Receive pictures uploaded from the camera
- Browse the pictures on the camera and download selected pictures
- Upload location data to the camera
- Release the camera shutter
- Update camera firmware

For downloads and other information, visit:

http://app.fujifilm-dsc.com/en/camera_remote/

Smartphones and Tablets: Bluetooth® Pairing

Use **CONNECTION SETTING** > **Bluetooth SETTINGS** > **PAIRING REGISTRATION** to pair the camera with smartphones or tablets. Pairing offers a simple method for downloading photos from the camera.



- Photos are downloaded via a wireless connection.
- Once pairing is complete, you will be able to synchronize the camera clock and location data with the smartphone or tablet (🗨️ 174).
- You can choose a connection from up to 7 paired smartphones or tablets.

Smartphones and Tablets: Wireless LAN

Use the **WIRELESS COMMUNICATION** options in **SHOOTING SETTING** or the playback menu to connect to a smartphone or tablet via a Wireless LAN.



Copying Pictures to a Computer: PC AutoSave

Install the latest version of FUJIFILM PC Autosave to your computer to upload pictures from the camera over wireless networks (Wi-Fi).

FUJIFILM PC AutoSave

For downloads and other information, visit:
http://app.fujifilm-dsc.com/en/pc_autosave/

Computers: Wireless Connections

You can upload pictures from the camera using the **PC AUTO SAVE** option in the playback menu.



Connecting via USB

The camera can be connected to computers and smart-phones via USB.

Connecting to Computers

Connect the camera and computer using the supplied USB cable.

 Before downloading pictures or taking pictures remotely, connect the camera to a computer and check that it functions normally.

- 1 Turn the computer on.
- 2 Adjust settings according to whether you will be copying pictures to a computer (📖 205).
- 3 Turn the camera off.
- 4 Connect a USB cable.

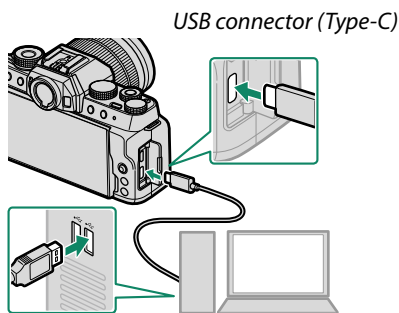

 The USB cable must be no more than 1.5 m (4.9 ft.) long and be suitable for data transfer.

- 5 Turn the camera on.

6 Copy pictures to your computer.

Use applications provided with your operating system.

- ❗ • Turn the camera off before disconnecting the USB cable.
- When connecting USB cables, be sure the connectors are fully inserted in the correct orientation. Connect the camera directly to the computer; do not use a USB hub or keyboard.
- Loss of power during transfer could result in loss of data or damage to the memory card. Insert a fresh or fully-charged battery before connecting the camera.
- If a memory card containing a large number of images is inserted, there may be a delay before the software starts and you may be unable to import or save images. Use a memory card reader to transfer pictures.
- Make sure that the indicator lamp is off or lit green before turning the camera off.
- Do not disconnect the USB cable while transfer is in progress. Failure to observe this precaution could result in loss of data or damage to the memory card.
- Disconnect the camera before inserting or removing memory cards.
- In some cases, it may not be possible to access pictures saved to a network server using the software in the same way as on a stand-alone computer.
- Do not immediately remove the camera from the system or disconnect the USB cable once the message stating that copying is in progress clears from the computer display. If the number of images copied is very large, data transfer may continue after the message has ceased to be displayed.
- The user bears all applicable fees charged by the phone company or Internet service provider when using services that require an Internet connection.

Copying Pictures to a Computer

- Before copying pictures to a computer, select **ON** for **☑ CONNECTION SETTING > USB IMAGE TRANSFER SETTING**.
- The software that can be used to copy pictures varies with your computer operating system.

Mac OS X/macOS

Pictures can be copied to your computer using Image Capture (supplied with your computer) or other software.

! Use a card reader to copy files over 4 GB in size.

Windows

Pictures can be copied to your computer using applications supplied with the operating system or other software.

Connecting to Smartphones

To copy pictures to a smartphone, select **ON** for **☑ CONNECTION SETTING > USB IMAGE TRANSFER SETTING** and connect the camera to the phone using a USB cable.

For Customers Using Android Devices

How you will connect the camera depends on the type of USB connector with which your smartphone is equipped.

Type-C

Ready a cable equipped with connectors matching the USB (Type-C) connector on the camera.



Micro-B

Use a USB on-the-go (OTG) cable.

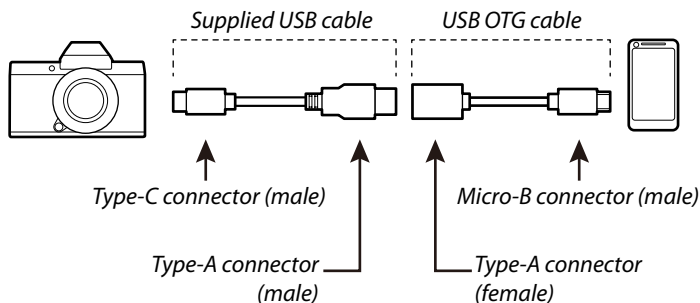

- ! The smartphone must support USB OTG.
- The desired results cannot be achieved with a USB Type-C-to-Micro-B cable. Use an OTG cable.

1 Set the camera's **CONNECTION SETTING > USB IMAGE TRANSFER SETTING** to **ON**.

2 Connect the camera and smartphone using a USB cable.

- If the smartphone asks for permission for an application other than the "Camera Importer" to access the camera, tap "Cancel" and move on to the next step.

3 On your smartphone, tap the notification "Connected to USB PTP".

4 From the recommended applications, select "Camera Importer".

The app will automatically start and allow you to import photos and movies to your smartphone.

- If the message "There is no MTP device connected" appears on the app, please try again from step 2.

For Customers Using iOS

An Apple Lightning to USB Camera Adapter is required.

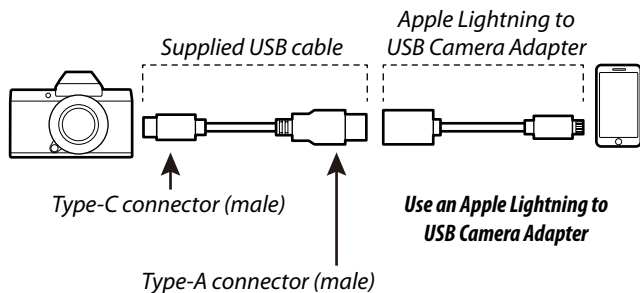

- 1 Set the camera's **CONNECTION SETTING > USB IMAGE TRANSFER SETTING** to ON.
- 2 Connect the camera and smartphone using a USB cable. The "Photos" app will automatically start and allow you to import photos and movies to your smartphone.

! The desired results cannot be achieved with a USB Type-C-to-Lightning cable. Use a camera adapter.

instax SHARE Printers

Print pictures from your digital camera to instax SHARE printers.

Establishing a Connection

Select **CONNECTION SETTING** > **instax PRINTER CONNECTION SETTING** in the camera setup menu and enter the instax SHARE printer name (SSID) and password.

The Printer Name (SSID) and Password

The printer name (SSID) can be found on the bottom of the printer; the default password is "1111". If you have already chosen a different password to print from a smartphone, enter that password instead.

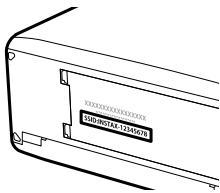

Printing Pictures

- 1 Turn the printer on.
- 2 Select **PLAY BACK MENU** > **instax PRINTER PRINT**. The camera will connect to the printer.



- 3 Use the focus stick (focus lever) to display the picture you want to print, then press **MENU/OK**.



- Pictures taken with other cameras cannot be printed.
- The area printed is smaller than the area visible in the LCD monitor.
- The displays may vary depending on the printer connected.



- 4 The picture will be sent to the printer and printing will start.

12

Technical Notes

Accessories from Fujifilm

The following optional accessories are available from Fujifilm. For the latest information on the accessories available in your region, check with your local Fujifilm representative or visit <https://fujifilm-x.com/accessories/>.

Rechargeable Li-ion batteries

NP-W126S: Additional high-capacity NP-W126S rechargeable batteries can be purchased as required.

Battery chargers

BC-W126S: Replacement battery chargers can be purchased as required. At +20 °C/+68 °F, the BC-W126S charges an NP-W126S in about 150 minutes.

AC power adapters

AC-9V (requires CP-W126 DC coupler): Use this 100–240 V, 50/60 Hz AC power adapter for extended shooting and playback or when copying pictures to a computer.

DC couplers

CP-W126: For extended shooting or playback or when using the camera with a computer, use the CP-W126 to connect the camera to the AC-9V power adapter.

Remote releases

RR-100: Use to reduce camera shake or keep the shutter open during a time exposure. The RR-100 has a connector with a diameter of 2.5 mm; a third-party \varnothing 2.5 mm to 3.5 mm adapter is required for connection to the camera.

Stereo microphones

MIC-ST1: An external microphone for movie recording.

FUJINON lenses

XF-/XC-series lenses: Interchangeable lenses for use exclusively with the FUJIFILM X-mount.

Macro extension tubes

MCEX-11/16: Attach between the camera and the lens to shoot at high reproduction ratios.

Teleconverters

XF1.4X TC WR: Increases the focal length of the compatible lenses by about 1.4x.

XF2X TC WR: Increases the focal length of the compatible lenses by about 2.0x.

Mount adapters

FUJIFILM M MOUNT ADAPTER: Allows the camera to be used with a wide selection of M-mount lenses.

Body caps

BCP-001: Cover the camera lens mount when no lens is attached.

Shoe-mounted flash units

EF-X500: This clip-on flash unit has a Guide Number of 50/164 (ISO 100, m/ft.) and is powered by four AA batteries or an optional EF-BP1 battery pack.

EF-BP1: A battery pack for shoe-mounted flash units. Takes up to 8 AA batteries.

EF-42: This clip-on flash unit has a Guide Number of 42/137 (ISO 100, m/ft.) and supports manual and TTL flash control.

EF-X20: This clip-on flash unit has a Guide Number of 20/65 (ISO 100, m/ft.) and supports manual and TTL flash control.

EF-20: This clip-on flash unit has a Guide Number of 20/65 (ISO 100, m/ft.) and supports TTL flash control (manual flash control is not supported).

Grip belts

GB-001: Offers an enhanced grip.

instax SHARE printers

SP-1/SP-2/SP-3: Connect via wireless LAN to print pictures on instax film.

Software from Fujifilm

The camera can be used with the following Fujifilm software.

FUJIFILM Camera Remote

Establish a wireless connection between your camera and a smartphone or tablet (📖 200).

http://app.fujifilm-dsc.com/en/camera_remote/

FUJIFILM PC AutoSave

Download pictures from your camera over wireless networks (📖 202).

http://app.fujifilm-dsc.com/en/pc_autosave/

Capture One Express Fujifilm

Capture One Express Fujifilm is image edit software from Phase One A/S. View RAW pictures on your computer and convert them into other formats. Capture One Express Fujifilm is available free of charge from Phase One.

<https://www.captureone.com/products/express/fujifilm>

RAW FILE CONVERTER EX

View RAW pictures on your computer and convert them into other formats.

<https://fujifilm-x.com/software/raw-file-converter-ex-powered-by-silkypix/>



“RAW FILE CONVERTER EX” is supplied by Ichikawa Soft Laboratory Co., Ltd.

For Your Safety

IMPORTANT SAFETY INSTRUCTIONS

- **Read Instructions:** All the safety and operating instructions should be read before the appliance is operated.
- **Retain Instructions:** The safety and operating instructions should be retained for future reference.
- **Heed Warnings:** All warnings on the appliance and in the operating instructions should be adhered to.
- **Follow Instructions:** All operating and use instructions should be followed.

Installation

Power Sources: This video product should be operated only from the type of power source indicated on the marking label. If you are not sure of the type of power supply to your home, consult your appliance dealer or local power company. For video products intended to operate from battery power, or other sources, refer to the operating instructions.

Grounding or Polarization: This video product is equipped with a polarized alternating-current line plug (a plug having one blade wider than the other). This plug will fit into the power outlet only one way. This is a safety feature. If you are unable to insert the plug fully into the outlet, try reversing the plug. If the plug should still fail to fit, contact your electrician to replace your obsolete outlet. Do not defeat the safety purpose of the polarized plug.

Alternate Warnings: This video product is equipped with a three-wire grounding-type plug, a plug having a third (grounding) pin. This plug will only fit into a grounding-type power outlet. This is a safety feature. If you are unable to insert the plug into the outlet, contact your electrician to replace your obsolete outlet. Do not defeat the safety purpose of the grounding type plug.

Overloading: Do not overload wall outlets and extension cords as this can result in a risk of fire or electric shock.

Ventilation: Slots and openings in the cabinet are provided for ventilation, to ensure reliable operation of the video product and to protect it from overheating, and these openings must not be blocked or covered. The openings should never be blocked by placing the video product on a bed, sofa, rug, or other similar surface.

This video product should not be placed in a built-in installation such as a bookcase or rack unless proper ventilation is provided or the manufacturer's instructions have been adhered to. This video product should never be placed near or over a radiator or heat register.

Attachments: Do not use attachments not recommended by the video product manufacturer as they may cause hazards.

Water and Moisture: Do not use this video product near water—for example, near a bath tub, wash bowl, kitchen sink, or laundry tub, in a wet basement, or near a swimming pool, and the like.

Power-Cord Protection: Power-supply cords should be routed so that they are not likely to be walked on or pinched by items placed upon or against them, paying particular attention to cords at plugs, convenience receptacles, and the point where they exit from the appliance.

Accessories: Do not place this video product on an unstable cart, stand, tripod, bracket, or table. The video product may fall, causing serious injury to a child or adult, and serious damage to the appliance. Use only with a cart, stand, tripod, bracket, or table recommended by the manufacturer, or sold with the video product. Any mounting of the appliance should follow the manufacturer's instructions, and should use a mounting accessory recommended by the manufacturer.

An appliance and cart combination should be moved with care. Quick stops, excessive force, and uneven surfaces may cause the appliance and cart combination to overturn.



Antennas

Outdoor Antenna Grounding: If an outside antenna or cable system is connected to the video product, be sure the antenna or cable system is grounded so as to provide some protection against voltage surges and built-up static charges. Section 810 of the National Electrical Code, ANSI/NFPA No. 70, provides information with respect to proper grounding of the mast and supporting structure, grounding of the lead-in wire to an antenna discharge unit, size of grounding conductors, location of antenna discharge unit, connection to grounding electrodes, and requirements for the grounding electrode.

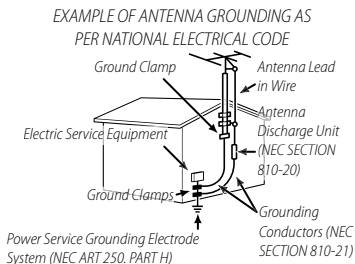

Power Lines: An outside antenna system should not be located in the vicinity of overhead power lines or other electric light or power circuits, or where it can fall into such power lines or circuits. When installing an outside antenna system, extreme care should be taken to keep from touching such power lines or circuits as contact with them might be fatal.

Use

Cleaning: Unplug this video product from the wall outlet before cleaning. Do not use liquid cleaners or aerosol cleaners. Use a damp cloth for cleaning.

Object and Liquid Entry: Never push objects of any kind into this video product through openings as they may touch dangerous voltage points or short out parts that could result in a fire or electric shock. Never spill liquid of any kind on the video product.

Lightning: For added protection for this video product receiver during a lightning storm, or when it is left unattended and unused for long periods of time, unplug it from the wall outlet and disconnect the antenna or cable system. This will prevent damage to the video product due to lightning and power-line surges.

Service

Servicing: Do not attempt to service this video product yourself as opening or removing covers may expose you to dangerous voltage or other hazards. Refer all servicing to qualified service personnel.

Damage Requiring Service: Unplug this video product from the wall outlet and refer servicing to qualified service personnel under the following conditions:

- When the power-supply cord or plug is damaged
- If liquid has been spilled, or objects have fallen into the video product.
- If the video product has been exposed to rain or water.
- If the video product has been dropped or the cabinet has been damaged.

If the video product does not operate normally follow the operating instructions. Adjust only those controls that are covered by the operating instructions as an improper adjustment of other controls may result in damage and will often require extensive work by a qualified technician to restore the video product to its normal operation.

When the video product exhibits a distinct change in performance — this indicates a need for service.

Replacement Parts: When replacement parts are required, be sure the service technician has used replacement parts specified by the manufacturer or have the same characteristics as the original part. Unauthorized substitutions may result in fire, electric shock or other hazards.



Safety Check: Upon completion of any service or repairs to this video product, ask the service technician to perform safety checks to determine that the video product is in proper operating condition.

Be sure to read these notes before use**Safety Notes**



- Make sure that you use your camera correctly. Read these safety notes and your *Basic Manual* carefully before use.
- After reading these safety notes, store them in a safe place.

About the Icons



The icons shown below are used in this document to indicate the severity of the injury or damage that can result if the information indicated by the icon is ignored and the product is used incorrectly as a result.

	WARNING	This icon indicates that death or serious injury can result if the information is ignored.
	CAUTION	This icon indicates that personal injury or material damage can result if the information is ignored.













The icons shown below are used to indicate the nature of the instructions which are to be observed.

















	Triangular icons tell you that this information requires attention ("Important").
	Circular icons with a diagonal bar tell you that the action indicated is prohibited ("Prohibited").
	Filled circles with an exclamation mark indicate an action that must be performed ("Required").

The symbols on the product (including the accessories) represent the following:

	AC
	DC
	Class II equipment (The construction of the product is double-insulated.)

 **WARNING**

 Unplug from power socket	<p><u>If a problem arises, turn the camera off, remove the battery, disconnect the USB cable, and unplug the AC power adapter.</u> Continued use of the camera when it is emitting smoke, is emitting any unusual odor, or is in any other abnormal state can cause a fire or electric shock. Contact your Fujifilm dealer.</p>
	<p><u>Do not allow water or foreign objects to enter the camera or connecting cables.</u> Do not use the camera or connecting cables following ingress of fresh or salt water, milk, beverages, detergents, or other liquids. Should liquid find its way into the camera or connecting cables, turn the camera off, remove the battery, disconnect the USB cable, and disconnect and unplug the AC adapter. Continued use of the camera can cause a fire or electric shock. Contact your Fujifilm dealer.</p>
 Do not use in the bathroom or shower	<p><u>Do not use the camera in the bathroom or shower.</u> This can cause a fire or electric shock.</p>
 Do not disassemble	<p><u>Never attempt to change or take apart the camera (never open the case).</u> Failure to observe this precaution can cause fire or electric shock.</p>
 Do not touch internal parts	<p><u>Should the case break open as the result of a fall or other accident, do not touch the exposed parts.</u> Failure to observe this precaution could result in electric shock or in injury from touching the damaged parts. Remove the battery immediately, taking care to avoid injury or electric shock, and take the product to the point of purchase for consultation.</p>
	<p><u>Do not change, heat or unduly twist or pull the connection cord and do not place heavy objects on the connection cord.</u> These actions could damage the cord and cause a fire or electric shock. If the cord is damaged, contact your Fujifilm dealer. Do not use cables with bent connectors.</p>
	<p><u>Do not place the camera on an unstable surface.</u> This can cause the camera to fall or tip over and cause injury.</p>
	<p><u>Never attempt to take pictures while in motion.</u> Do not use the camera while walking or driving. This can result in you falling down or being involved in a traffic accident.</p>
	<p><u>Do not touch any metal parts of the camera during a thunderstorm.</u> This can cause an electric shock due to induced current from the lightning discharge.</p>
	<p><u>Do not use the battery except as specified.</u> Load the battery as shown by the indicator.</p>
	<p><u>Do not disassemble, modify, or heat batteries. Do not drop, strike, or throw batteries or otherwise subject them to strong impacts. Do not use batteries that show signs of leaking, deformation, discoloration, or other abnormalities. Use only designated chargers to recharge rechargeable batteries and do not attempt to recharge non-rechargeable Li-ion or alkaline batteries. Do not short batteries or store them with metallic objects.</u> Failure to observe these precautions could result in the batteries overheating, igniting, rupturing, or leaking, causing fire, burns, or other injury.</p>
	<p><u>Use only batteries or AC power adapters specified for use with this camera. Do not use voltages other than the power supply voltage shown.</u> The use of other power sources can cause a fire.</p>
	<p><u>If the battery leaks and fluid gets in contact with your eyes, skin or clothing, flush the affected area with clean water and seek medical attention or call an emergency number right away.</u></p>

 WARNING	
	<u>Do not use the charger to charge batteries other than those specified here.</u> The supplied charger is for use only with batteries of the type supplied with the camera. Using the charger to charge conventional batteries or other types of rechargeable batteries can cause the battery to leak, overheat or burst.
	<u>Using a flash too close to a person's eyes may cause visual impairment.</u> Take particular care when photographing infants and young children.
	<u>Do not remain in prolonged contact with hot surfaces.</u> Failure to observe this precaution could result in low-temperature burns, particularly at high ambient temperatures or with users who suffer from poor circulation or reduced sensation, in which case use of a tripod or similar precautions are recommended.
	<u>Do not leave one part of the body in contact with the product for prolonged periods while the product is on.</u> Failure to observe this precaution could result in low-temperature burns, particularly during prolonged use, at high ambient temperatures, or with users who suffer from poor circulation or reduced sensation, in which case use of a tripod or similar precautions are recommended.
	<u>Do not use in the presence of flammable objects, explosive gases, or dust.</u>
	<u>When carrying the battery, install it in a digital camera or keep it in the hard case. When storing the battery, keep it in the hard case. When discarding, cover the battery terminals with insulation tape.</u> Contact with other metallic objects or batteries could cause the battery to ignite or burst.
	<u>Keep memory cards, hot shoes, and other small parts out of the reach of small children.</u> Children may swallow small parts; keep out of reach of children. Should a child swallow a small part, seek medical attention or call emergency.
	<u>Keep out of reach of small children.</u> Among the elements that could cause injury are the strap, which could become entangled about a child's neck, causing strangulation, and the flash, which could cause visual impairment.
	<u>Follow the directions of airline and hospital personnel.</u> This product generates radio-frequency emissions that could interfere with navigational or medical equipment.
 CAUTION	
	<u>Do not use this camera in locations affected by oil fumes, steam, humidity or dust.</u> This can cause a fire or electric shock.
	<u>Do not leave this camera in places subject to extremely high temperatures.</u> Do not leave the camera in locations such as a sealed vehicle or in direct sunlight. This can cause a fire.
	<u>Do not place heavy objects on the camera.</u> This can cause the heavy object to tip over or fall and cause injury.
	<u>Do not move the camera while the AC power adapter is still connected.</u> Do not pull on the connection cord to disconnect the AC power adapter. This can damage the power cord or cables and cause a fire or electric shock.
	<u>Do not cover or wrap the camera or the AC power adapter in a cloth or blanket.</u> This can cause heat to build up and distort the casing or cause a fire.
	<u>Do not use the plug if it is damaged or if it does not fit securely into the outlet.</u> Failure to observe this precaution could result in fire or electric shock.

⚠ CAUTION



When you are cleaning the camera or you do not plan to use the camera for an extended period, remove the battery and disconnect and unplug the AC power adapter. Failure to do so can cause a fire or electric shock.



When charging ends, unplug the charger from the power socket. Leaving the charger plugged into the power socket can cause a fire.



When a memory card is removed, the card could come out of the slot too quickly. Use your finger to hold it and gently release the card. Injury could result to those struck by the ejected card.



Request regular internal testing and cleaning for your camera. Build-up of dust in your camera can cause a fire or electric shock. Contact your Fujifilm dealer to request internal cleaning every two years. Please note that this service is not free of charge.



Danger of explosion if battery is incorrectly replaced. Replace only with the same or equivalent type.



Batteries (battery pack or batteries installed) shall not be exposed to excessive heat such as sunshine, fire or the like.

The Battery and Power Supply

Note: Check the type of battery used in your camera and read the appropriate sections.

⚠ WARNING: Battery shall not be exposed to excessive heat such as sunshine, fire or the like.

The following describes the proper use of batteries and how to prolong their life. Incorrect use can shorten battery life or cause leakage, overheating, fire, or explosion.

Li-ion Batteries

Read this section if your camera uses a rechargeable Li-ion battery.

The battery is not charged at shipment. Charge the battery before use. Keep the battery in its case when not in use.

■ Notes on the Battery

The battery gradually loses its charge when not in use. Charge the battery one or two days before use.

Battery life can be extended by turning the camera off when not in use.

Battery capacity decreases at low temperatures; a depleted battery may not function when cold. Keep a fully charged spare battery in a warm place and exchange as necessary, or keep the battery in your pocket or other warm place and insert it in the camera only when shooting. Do not place the battery in direct contact with hand warmers or other heating devices.

■ Charging the Battery

The battery can be charged using a BC-W126S battery charger (available separately). Charging times will increase at ambient temperatures below +10°C (+50°F) or above +35°C (+95°F). Do not attempt to charge the battery at temperatures above +40°C (+104°F); at temperatures below +5°C (+41°F), the battery will not charge.

Do not attempt to recharge a fully charged battery. The battery does not however need to be fully discharged before charging.

The battery may be warm to the touch immediately after charging or use. This is normal.

■ Battery Life

At normal temperatures, the battery can be recharged about 300 times. A noticeable decrease in the length of time the battery will hold a charge indicates that it has reached the end of its service life and should be replaced.

■ Storage

Performance may be impaired if the battery is left unused for extended periods when fully charged. Run the battery flat before storing it.

If the camera will not be used for an extended period, remove the battery and store it in a dry place with an ambient temperature of from +15°C to +25°C (+59°F to +77°F). Do not store in locations exposed to extremes of temperature.

■ Cautions: Handling the Battery

- Do not transport or store with metal objects such as necklaces or hairpins.
- Do not expose to flame or heat.
- Do not disassemble or modify.
- Use with designated chargers only.
- Dispose of used batteries promptly.
- Do not drop or subject to strong physical shocks.
- Do not expose to water.
- Keep the terminals clean.
- The battery and camera body may become warm to the touch after extended use. This is normal.

■ Caution: Disposal

Dispose of used batteries in accord with local regulations. Attention should be drawn to the environmental aspects of battery disposal. Use the apparatus under moderate climate.

Using the Camera

- Do not aim the camera at extremely bright light sources, including artificial light sources or natural light sources such as the sun in a cloudless sky. Failure to observe this precaution could damage the camera image sensor.
- Strong sunlight focused through the viewfinder may damage the panel of electronic viewfinder (EVF). Do not aim the electronic viewfinder at the sun.

Take Test Shots

Before taking photographs on important occasions (such as at weddings or before taking the camera on a trip), take a test shot and view the results to ensure that the camera is functioning normally. FUJIFILM Corporation cannot accept liability for damages or lost profits incurred as a result of product malfunction.

Notes on Copyright

Unless intended solely for personal use, images recorded using your digital camera system cannot be used in ways that infringe copyright laws without the consent of the owner. Note that some restrictions apply to the photographing of stage performances, entertainments, and exhibits, even when intended purely for personal use. Users are also asked to note that the transfer of memory cards containing images or data protected under copyright laws is only permissible within the restrictions imposed by those copyright laws.

Handling

To ensure that images are recorded correctly, do not subject the camera to impact or physical shocks while images are being recorded.

Liquid Crystal

In the event that the display is damaged, care should be taken to avoid contact with liquid crystal. Take the urgent action indicated should any of the following situations arise:

- **If liquid crystal comes in contact with your skin**, clean the area with a cloth and then wash thoroughly with soap and running water.
- **If liquid crystal enters your eyes**, flush the affected eye with clean water for at least 15 minutes and then seek medical assistance.
- **If liquid crystal is swallowed**, rinse your mouth thoroughly with water. Drink large quantities of water and induce vomiting, then seek medical assistance.

Although the display is manufactured using extremely high-precision technology, it may contain pixels that are always lit or that do not light. This is not a malfunction, and images recorded with the product are unaffected.

Trademark Information

Digital Split Image is a trademark or registered trademark of FUJIFILM Corporation. Digital Micro Prism is a trademark or registered trademark of FUJIFILM Corporation. The typefaces included herein are solely developed by DynaComware Taiwan Inc. Apple, iPhone, iPad, Mac, OS X, macOS and Lightning are registered trademarks of Apple Inc. in the U.S.A. and other countries. Windows is a registered trademark of Microsoft Corporation in the U.S.A. and other countries. Android is a trademark or registered trademark of Google LLC. Adobe, the Adobe logo, Photoshop, and Lightroom are trademarks or registered trademarks of Adobe Systems Incorporated in the U.S.A. and other countries. Wi-Fi® and Wi-Fi Protected Setup® are registered trademarks of the Wi-Fi Alliance. The Bluetooth® word mark and logos are registered trademarks owned by the Bluetooth SIG, Inc., and any use of such marks by Fujifilm is under license. The SDHC and SDXC logos are trademarks of SD-3C, LLC. The HDMI logo is a trademark or registered trademark of HDMI Licensing LLC. All other trade names mentioned in this manual are the trademarks or registered trademarks of their respective owners.

Electrical Interference

This camera may interfere with hospital or aviation equipment. Consult with hospital or airline staff before using the camera in a hospital or on an aircraft.

Color Television Systems

NTSC (National Television System Committee) is a color television telecasting specification adopted mainly in the U.S.A., Canada, and Japan. PAL (Phase Alternation by Line) is a color television system adopted mainly in European countries and China.

Exif Print (Exif Version 2.3)

Exif Print is a newly revised digital camera file format in which information stored with photographs is used for optimal color reproduction during printing.

IMPORTANT NOTICE: Read Before Using the Software

Direct or indirect export, in whole or in part, of licensed software without the permission of the applicable governing bodies is prohibited.

Lenses and Other Accessories

- Use a screw 4.5 mm or shorter when attaching a tripod.
- Fujifilm will not be held liable for performance issues or damage caused by the use of third-party accessories.

NOTICES

To prevent fire or shock hazard, do not expose the unit to rain or moisture.

Please read the "Safety Notes" and make sure you understand them before using the camera.

Perchlorate Material—special handling may apply. See:

<http://www.dtsc.ca.gov/hazardouswaste/perchlorate>

For Customers in the U. S. A.

Tested To Comply With FCC Standards**FOR HOME OR OFFICE USE**

Contains IC : 7736B-02100005

Contains FCC ID : W2Z-02100005

FCC Statement: This device complies with Part 15 of the FCC Rules. Operation is subject to the following two conditions: (1) This device may not cause harmful interference, and (2) this device must accept any interference received, including interference that may cause undesired operation.

CAUTION: This equipment has been tested and found to comply with the limits for a Class B digital device, pursuant to Part 15 of the FCC Rules. These limits are designed to provide reasonable protection against harmful interference in a residential installation. This equipment generates, uses, and can radiate radio frequency energy and, if not installed and used in accordance with the instructions, may cause harmful interference to radio communications. However, there is no guarantee that interference will not occur in a particular installation. If this equipment does cause harmful interference to radio or television reception, which can be determined by turning the equipment off and on, the user is encouraged to try to correct the interference by one or more of the following measures:

- Reorient or relocate the receiving antenna.
- Increase the separation between the equipment and receiver.
- Connect the equipment into an outlet on a circuit different from that to which the receiver is connected.
- Consult the dealer or an experienced radio/TV technician for help.

FCC Caution: Any changes or modifications not expressly approved by the party responsible for compliance could void the user's authority to operate this equipment.

This transmitter must not be co-located or operating in conjunction with any other antenna or transmitter.

Radiation Exposure Statement: This device meets the government's requirements for exposure to radio waves. This device is designed and manufactured not to exceed the emission limits for exposure to radio frequency (RF) energy set by the Federal Communications Commission of the U.S. Government.

The exposure standard for wireless device employs a unit of measurement known as the Specific Absorption Rate, or SAR. The SAR limit set by the FCC is 1.6W/kg. Tests for SAR are conducted using standard operating positions accepted by the FCC with the device transmitting at its highest certified power level in all tested frequency bands.

Notes on the Grant: To comply with Part 15 of the FCC Rules, this product must be used with a Fujifilm-specified ferrite-core A/V cable, USB cable, and DC supply cord.



A lithium ion battery that is recyclable powers the product you have purchased. Please call 1-800-8-BATTERY for information on how to recycle this battery.



California Code of Regulations, Title 20, Division 2, Chapter 4, Article 4, Appliance Efficiency Regulations, Sections 1601 through 1609

For Customers in Canada

CAN ICES-3 (B)/NMB-3(B)

CAUTION: This Class B digital apparatus complies with Canadian ICES-003.

Industry Canada statement: This device complies with Industry Canada's licence-exempt RSSs. Operation is subject to the following two conditions: (1) This device may not cause interference; and (2) This device must accept any interference, including interference that may cause undesired operation of the device.

This device and its antenna(s) must not be co-located or operating in conjunction with any other antenna or transmitter, except tested built-in radios. The County Code Selection feature is disabled for products marketed in the US/ Canada.

Radiation Exposure Statement: The available scientific evidence does not show that any health problems are associated with using low power wireless devices. There is no proof, however, that these low power wireless devices are absolutely safe. Low power Wireless devices emit low levels of radio frequency energy (RF) in the microwave range while being used. Whereas high levels of RF can produce health effects (by heating tissue), exposure of low-level RF that does not produce heating effects causes no known adverse health effects. Many studies of low-level RF exposures have not found any biological effects. Some studies have suggested that some biological effects might occur, but such findings have not been confirmed by additional research. X-T200 has been tested and found to comply with IC radiation exposure limits set forth for an uncontrolled environment and meets RSS-102 of the IC radio frequency (RF) Exposure rules.

Disposal of Electrical and Electronic Equipment in Private Households

In the European Union, Norway, Iceland and Liechtenstein: This symbol on the product, or in the manual and in the warranty, and/or on its packaging indicates that this product shall not be treated as household waste. Instead it should be taken to an applicable collection point for the recycling of electrical and electronic equipment.



By ensuring this product is disposed of correctly, you will help prevent potential negative consequences to the environment and human health, which could otherwise be caused by inappropriate waste handling of this product.

This symbol on the batteries or accumulators indicates that those batteries shall not be treated as household waste.



If your equipment contains easy removable batteries or accumulators please dispose these separately according to your local requirements.

The recycling of materials will help to conserve natural resources. For more detailed information about recycling this product, please contact your local city office, your household waste disposal service or the shop where you purchased the product.

In Countries Outside the European Union, Norway, Iceland and Liechtenstein: If you wish to discard this product, including the batteries or accumulators, please contact your local authorities and ask for the correct way of disposal.

In Japan: This symbol on the batteries indicates that they are to be disposed of separately.



Wireless Network and Bluetooth Devices: Cautions

This product complies with the following EU Directives:

- RoHS Directive 2011/65/EU
- RE Directive 2014/53/EU

Hereby, FUJIFILM Corporation declares that the radio equipment type FF190004 is in compliance with Directive 2014/53/EU.

The full text of the EU declaration of conformity is available at the following internet address:

https://dl.fujifilm-x.com/global/products/cameras/x-t200/pdf/x-t200_doc-ismr.pdf

This compliance is indicated by the following conformity marking placed on the product:



This marking is valid for non-Telecom products and EU harmonized Telecom products (e.g. Bluetooth®).

IMPORTANT: Read the following notices before using the camera's built-in wireless transmitter.

- ① This product, which contains encryption function developed in the United States, is controlled by the United States Export Administration Regulations and may not be exported or re-exported to any country to which the United States embargoes goods.
- **Use only a wireless network or Bluetooth device.** Fujifilm does not accept liability for damages resulting from unauthorized use. Do not use in applications requiring a high degree of reliability, for example in medical devices or other systems that may directly or indirectly impact human life. When using the device in computer and other systems that demand a greater degree of reliability than offered by wireless network or Bluetooth devices, be sure to take all necessary precautions to ensure safety and prevent malfunction.
- **Use only in the country in which the device was purchased.** This device conforms to regulations governing wireless network and Bluetooth devices in the country in which it was purchased. Observe all location regulations when using the device. Fujifilm does not accept liability for problems arising from use in other jurisdictions.

- **Do not use the device in locations subject to magnetic fields, static electricity, or radio interference.** Do not use the transmitter in the vicinity of microwave ovens or in other locations subject to magnetic fields, static electricity, or radio interference that may prevent reception of wireless signals. Mutual interference may occur when the transmitter is used in the vicinity of other wireless devices operating in the 2.4 GHz band.
- **The wireless transmitter operates in the 2.4 GHz band using DSSS, OFDM and GFSK modulation.**
- **Security:** Wireless network and Bluetooth devices transmit data via radio and consequently their use requires greater attention to security than applies in the case of wired networks.
 - Do not connect to unknown networks or networks to which you do not have access rights, even if they are displayed on your device, as such access may be considered unauthorized. Connect only to networks to which you have access rights.
 - Be aware that wireless transmissions may be vulnerable to interception by third parties.
- **The following may be punishable by law:**
 - Disassembly or modification of this device
 - Removal of device certification labels
- **This device operates on the same frequency as commercial, educational, and medical devices and wireless transmitters.** It also operates on the same frequency as licensed transmitters and special unlicensed low-voltage transmitters used in RFID tracking systems for assembly lines and in other similar applications.
- **To prevent interference with the above devices, observe the following precautions.** Confirm that the RFID transmitter is not in operation before using this device. Should you observe that the device causes interference in licensed transmitters used for RFID tracking, immediately stop using the affected frequency or move the device to another location. If you notice that this device causes interference in low-voltage RFID tracing systems, contact a Fujifilm representative.
- **Do not use this device on board an aircraft.** Note that Bluetooth may remain on even when the camera is off. Bluetooth can be disabled by selecting **OFF** for **CONNECTION SETTING > Bluetooth SETTINGS > Bluetooth ON/OFF**.
- **Maximum radio-frequency power (EIRP):**
 WLAN 2.4 GHz: 9.71 dBm
 Bluetooth: 6.72 dBm



Be sure to read these notes before using the lens

Safety Notes



- Make sure that you use the lens correctly. Read these safety notes and the camera *Basic Manual* carefully before use.
- After reading these safety notes, store them in a safe place.

About the Icons





The icons shown below are used in this document to indicate the severity of the injury or damage that can result if the information indicated by the icon is ignored and the product is used incorrectly as a result.

	WARNING This icon indicates that death or serious injury can result if the information is ignored.
	CAUTION This icon indicates that personal injury or material damage can result if the information is ignored.







The icons shown below are used to indicate the nature of the instructions which are to be observed.

	Triangular icons tell you that this information requires attention ("Important").
	Circular icons with a diagonal bar tell you that the action indicated is prohibited ("Prohibited").
	Filled circles with an exclamation mark indicate an action that must be performed ("Required").

⚠ WARNING

 <small>Do not immerse</small>	<u>Do not immerse in or expose to water.</u> Failure to observe this precaution can cause a fire or electric shock.
 <small>Do not disassemble</small>	<u>Do not disassemble (do not open the case).</u> Failure to observe this precaution can cause fire, electric shock, or injury due to product malfunction.
 <small>Do not touch internal parts</small>	<u>Should the case break open as the result of a fall or other accident, do not touch the exposed parts.</u> Failure to observe this precaution could result in electric shock or in injury from touching the damaged parts. Remove the battery immediately, taking care to avoid injury or electric shock, and take the product to the point of purchase for consultation.
	<u>Do not place on unstable surfaces.</u> The product may fall, causing injury.
	<u>Do not view the sun through the lens or camera viewfinders.</u> Failure to observe this precaution can cause permanent visual impairment.

 **CAUTION**

	<i>Do not use or store in locations that are exposed to steam, or smoke or are very humid or extremely dusty.</i> Failure to observe this precaution can cause fire or electric shock.
	<i>Do not leave in direct sunlight or in locations subject to very high temperatures, such as in a closed vehicle on a sunny day.</i> Failure to observe this precaution can cause fire.
	<i>Keep out of the reach of small children.</i> This product could cause injury in the hands of a child.
	<i>Do not handle with wet hands.</i> Failure to observe this precaution can cause electric shock.
	<i>Keep the sun out of the frame when shooting backlit subjects.</i> Sunlight focused into the camera when the sun is in or close to the frame can cause fire or burns.
	<i>When the product is not in use, replace the lens caps and store out of direct sunlight.</i> Sunlight focused by the lens can cause fire or burns.
	<i>Do not carry the camera or lens while they are attached to a tripod.</i> The product can fall or strike other objects, causing injury.

Product Care

To ensure continued enjoyment of the product, observe the following precautions.

Camera body: Use a soft, dry cloth to clean the camera body after each use. Do not use alcohol, thinner, or other volatile chemicals, which could discolor or deform the leather on the camera body. Any liquid on the camera should be removed immediately with a soft, dry cloth. Use a blower to remove dust from the monitor, taking care to avoid scratches, and then gently wipe with a soft, dry cloth. Any remaining stains can be removed by wiping gently with a piece of Fujifilm lens-cleaning paper to which a small amount of lens-cleaning fluid has been applied. To prevent dust entering the camera, replace the body cap when no lens is in place.

Image sensor: Multiple photographs marred by spots or blotches in identical locations may indicate the presence of dust on the image sensor. Clean the sensor using  **USER SETTING > SENSOR CLEANING.**

Cleaning the Image Sensor

Dust that cannot be removed using **USER SETTING > SENSOR CLEANING** can be removed manually as described below.

! Note that there will be a charge to repair or replace the image sensor if it is damaged during cleaning.

- 1 Use a blower (not a brush) to remove dust from the sensor.

! Do not use a brush or blower brush. Failure to observe this precaution could damage the sensor.

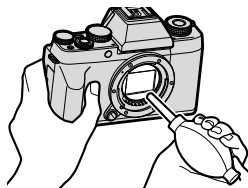

- 2 Check whether the dust has been successfully removed. Repeat Steps 1 and 2 as necessary.
- 3 Replace the body cap or lens.

Firmware Updates

Updates to product firmware may result in changes not described in the manual. For more information, visit: <https://fujifilm-x.com/support/download/firmware/>

Checking the Firmware Version

 The camera will only display the firmware version if a memory card is inserted.

- 1 Turn the camera off and check that a memory card is inserted.
- 2 Turn the camera on while holding the **DISP/BACK** button. The current firmware version will be displayed; check the firmware version.
- 3 Turn the camera off.

 To view the firmware version or update firmware for optional accessories such as interchangeable lenses, shoe-mounted flash units, and mount adapters, mount the accessories on the camera.

Troubleshooting

Consult the table below should you encounter problems using your camera. If you don't find the solution here, contact your local Fujifilm distributor.

Power and Battery

Problem	Solution
The camera does not turn on.	<ul style="list-style-type: none">• The battery is exhausted: Charge the battery or insert a fully-charged spare battery (📖 32).• The battery is inserted incorrectly: Reinsert in the correct orientation (📖 28).• The battery-chamber cover is not latched: Latch the battery-chamber cover (📖 28).
The battery runs down quickly.	<ul style="list-style-type: none">• The battery is cold: Warm the battery by placing it in a pocket or other warm place and reinsert it in the camera immediately before taking a picture.• There is dirt on the battery terminals: Clean the terminals with a soft, dry cloth.• ON is selected for PRE-AF: Choosing OFF for PRE-AF extends battery endurance (📖 106).• The camera is in S^+ mode: To extend battery endurance, we recommend that you choose a different mode (📖 52).• The battery has been charged many times: The battery has reached the end of its charging life. Purchase a new battery.
The camera turns off suddenly.	<ul style="list-style-type: none">• The battery is exhausted: Charge the battery or insert a fully-charged spare battery (📖 32).

Problem	Solution
Charging does not start (USB).	<ul style="list-style-type: none"> • Insert the camera battery (📖 28). • Reinsert the camera battery in the correct orientation (📖 28). • Confirm that the camera is connected to the computer (📖 32). • If the computer is off or in sleep mode, turn on or wake the computer and disconnect and reconnect the USB cable (📖 32).
Charging does not start (battery charger).	<ul style="list-style-type: none"> • Insert the battery. • Reinsert the battery in the correct orientation. • Make sure that the charger is correctly plugged in. • Ensure that the plug adapter is correctly connected to the charger.
Charging is slow.	Charge the battery at room temperature.
The indicator lamp blinks, but the battery does not charge.	<ul style="list-style-type: none"> • There is dirt on the battery terminals: Clean the terminals with a soft, dry cloth (📖 28). • The battery has been charged many times: The battery has reached the end of its charging life. Purchase a new battery. If the battery still fails to charge, contact your Fujifilm dealer (📖 210).

Menus and Displays

Problem	Solution
Display is not in English.	Select ENGLISH for 言語/LANG. (📖 38, 158).

Shooting

Problem	Solution
No picture is taken when the shutter button is pressed.	<ul style="list-style-type: none">• The memory card is full: Insert a new memory card or delete pictures (📖 28, 139).• The memory card is not formatted: Format the memory card (📖 156).• There is dirt on the memory card contacts: Clean the contacts with a soft, dry cloth.• The memory card is damaged: Insert a new memory card (📖 28).• The battery is exhausted: Charge the battery or insert a fully-charged spare battery (📖 32).• The camera has turned off automatically: Turn the camera on (📖 34).• You are using a third-party mount adapter: Select ON for SHOOT WITHOUT LENS (📖 169).• The indicator lamp was orange when you attempted to record a panorama: Wait until the indicator lamps turns off (📖 8, 60).
Mottling (“noise”) appears in the monitor or viewfinder when the shutter button is pressed halfway.	Gain is increased to aid composition when the subject is poorly lit and aperture is stopped down, which may result in noticeable mottling when images are previewed in the displays. Images taken with the camera are unaffected.
The camera does not focus.	The subject is not suited to autofocus: Use focus lock or manual focus (📖 80).

Problem	Solution
No face is detected.	<ul style="list-style-type: none"> • The subject's face is obscured by sunglasses, a hat, long hair, or other objects: Remove the obstructions (📖 107). • The subject's face occupies only a small area of the frame: Change the composition so that the subject's face occupies a larger area of the frame (📖 107). • The subject's head is tilted or horizontal: Ask the subject to hold their head straight (📖 107). • The camera is tilted: Keep the camera level. • The subject's face is poorly lit: Shoot in bright light.
Wrong subject is selected.	The selected subject is closer to the center of the frame than the main subject. Recompose the picture or turn face detection off and frame the picture using focus lock (📖 80).
The camera will not record movies.	The memory card write speed is too slow: Use a memory card with a UHS speed class of 3 or better (📖 31, 46).

Problem	Solution
The flash does not fire.	<ul style="list-style-type: none"> • The battery is exhausted: Charge the battery or insert a fully-charged spare battery (📖 32). • The camera is in bracketing or continuous mode: Select single frame mode (📖 5, 89, 92). • The flash is lowered: Raise the flash (📖 94). • OFF is selected for SOUND & FLASH: Select ON (📖 158).
The flash does not fully light the subject.	<ul style="list-style-type: none"> • The subject is not in range of the flash: Position the subject in range of the flash. • The flash window is obstructed: Hold the camera correctly. • Shutter speed is faster than the sync speed: Choose a slower shutter speed (📖 54, 57, 95, 245).
Pictures are blurred.	<ul style="list-style-type: none"> • The lens is dirty: Clean the lens (📖 196). • The lens is blocked: Keep objects away from the lens (📖 40). • !AF is displayed during shooting and the focus frame is displayed in red: Check focus before shooting (📖 41).
Pictures are mottled.	<ul style="list-style-type: none"> • Shutter speed is slow and the ambient temperature is high: This is normal and does not indicate a malfunction. • The camera has been used continuously at high temperatures or a temperature warning is displayed: Turn the camera off and wait for it to cool down (📖 34, 242).

Playback





Problem	Solution
Pictures are grainy.	The pictures were taken with a different make or model of camera.
Playback zoom is unavailable.	The pictures were created using RESIZE or with a different make or model of camera.
No sound in movie playback.	<ul style="list-style-type: none"> • Playback volume is too low: Adjust playback volume (📖 161). • The microphone was obstructed: Hold the camera correctly during recording. • The speaker is obstructed: Hold the camera correctly during playback. • OFF is selected for SOUND & FLASH: Select ON (📖 158).
Selected pictures are not deleted.	Some of the pictures selected for deletion are protected.
Pictures remain after ERASE > ALL FRAMES is selected.	Remove protection using the device with which it was originally applied (📖 144).
File numbering is unexpectedly reset.	The battery-chamber cover was opened while the camera was on. Turn the camera off before opening the battery-chamber cover (📖 172).

Connections

Problem	Solution
Both the TV and camera monitor are blank.	The display mode selected with the VIEW MODE button is EVF ONLY +  : Put your eye to the viewfinder or use the VIEW MODE button to choose another display mode (📖 13).
The monitor is blank.	The camera is connected to a TV: Pictures will be displayed on the TV instead of in the camera monitor (📖 198).
No picture or sound on TV.	<ul style="list-style-type: none"> • The camera is not properly connected: Connect the camera properly (📖 198). • Input on the television is set to “TV”: Set input to “HDMI” (📖 198). • The volume on the TV is too low: Use the controls on the television to adjust the volume (📖 198).
The computer does not recognize the camera.	Be sure the camera and computer are correctly connected (📖 203).
Pictures cannot be uploaded to computers or smartphones.	OFF is selected for USB IMAGE TRANSFER SETTING: Choose ON (📖 176, 205).
Cannot connect to smartphone.	Confirm that the camera is correctly connected: The procedure for connecting the camera varies with the type of connector with which the smartphone is equipped (📖 205).

Wireless Transfer

For additional information on troubleshooting wireless connections, visit: <http://digital-cameras.support.fujifilm.com/app?pid=x>



Problem	Solution
Smartphone will not display pictures.	Select ON for RESIZE IMAGE FOR SMARTPHONE  . Selecting OFF increases upload times for larger images; in addition, some phones may not display images over a certain size ( 177).
Cannot connect to smartphone. The camera is slow to connect or upload pictures to the smartphone. Upload fails or is interrupted.	<ul style="list-style-type: none"> • The smartphone is too far away: Move the devices closer ( 200). • Nearby devices are causing radio interference: Move the camera and smartphone away from microwave ovens or cordless phones ( 200).
Cannot upload images.	<ul style="list-style-type: none"> • The smartphone is connected to another device: The smartphone and camera can connect to only one device at a time. End the connection and try again. • There are several smartphones in the vicinity: Try connecting again. The presence of multiple smartphones can make connection difficult. • The image was created on another device: The camera may not be able to upload images created on other devices. • The image is a movie: Uploading movies takes some time. In addition, smartphones may not accept upload of movies in formats they do not support.

Miscellaneous

Problem	Solution
The camera is unresponsive.	<ul style="list-style-type: none"> • Temporary camera malfunction: Remove and reinsert the battery (📖 28). • The battery is exhausted: Charge the battery or insert a fully-charged spare battery (📖 32). • The camera is connected to a wireless LAN: End the connection.
The camera does not function as expected.	Remove and reinsert the battery (📖 28). If the problem persists, contact your Fujifilm dealer.
No sound.	<ul style="list-style-type: none"> • Adjust the volume (📖 160). • Select ON for SOUND & FLASH (📖 158).
Time and date stamps.	<ul style="list-style-type: none"> • Time and date stamps are not correct: Set the camera clock (📖 38, 157). • Time and date stamps appear on photographs: Time and date stamps cannot be deleted. To prevent stamps appearing on new photographs, select OFF for SAVE DATA SET-UP > DATE STAMP (📖 173).





Warning Messages and Displays

The following warnings appear in the display.

Warning	Description
 (red)	Low battery. Charge the battery or insert a fully-charged spare battery.
 (blinks red)	Battery exhausted. Charge the battery or insert a fully-charged spare battery.
!AF (displayed in red with red focus frame)	The camera cannot focus. Use focus lock to focus on another subject at the same distance, then recompose the picture.
Aperture or shutter speed displayed in red	The subject is too bright or too dark and the picture will be over- or under-exposed. Use the flash for additional lighting when taking photographs of poorly-lit subject.
FOCUS ERROR	Camera malfunction. Turn the camera off and then on again. If the message persists, contact a Fujifilm dealer.
LENS CONTROL ERROR	
TURN OFF THE CAMERA AND TURN ON AGAIN	
NO MEMORY CARD INSERT A NEW CARD	No memory card is inserted. Insert a memory card.







Warning	Description
CARD NOT INITIALIZED	<ul style="list-style-type: none"> • The memory card is not formatted or the memory card has been formatted in a computer or other device: Format the memory card using FORMAT. • The memory card contacts require cleaning: Clean the contacts with a soft, dry cloth. If the message is repeated, format the card. If the message persists, replace the card. • Camera malfunction: Contact a Fujifilm dealer.
LENS ERROR	<p>Turn the camera off, remove the lens, and clean the mounting surfaces, then replace the lens and turn the camera on. If the problem persists, contact a Fujifilm dealer.</p>
CARD ERROR	<ul style="list-style-type: none"> • The memory card is not formatted for use in the camera: Format the card. • The memory card contacts require cleaning or the memory card is damaged: Clean the contacts with a soft, dry cloth. If the message is repeated, format the card. If the message persists, replace the card. • Incompatible memory card: Use a compatible card. • Camera malfunction: Contact a Fujifilm dealer.
PROTECTED CARD	<p>The memory card is locked. Unlock the card.</p>

Warning	Description
BUSY	The memory card is incorrectly formatted. Use the camera to format the card.
SD MEMORY FULL	The memory card is full and pictures cannot be recorded. Delete pictures or insert a memory card with more free space.
WRITE ERROR	<ul style="list-style-type: none"> • Memory card error or connection error: Reinsert the card or turn the camera off and then on again. If the message persists, contact a Fujifilm dealer. • Not enough memory remaining to record additional pictures: Delete pictures or insert a memory card with more free space. • The memory card is not formatted: Format the memory card.
FRAME NO. FULL	The camera has run out of frame numbers (current frame number is 999-9999). Format the memory card and select RENEW for FRAME NO. . Take a picture to reset frame numbering to 100-0001, then select CONTINUOUS for FRAME NO.
READ ERROR	<ul style="list-style-type: none"> • The file is corrupt or was not created with the camera: The file cannot be viewed. • The memory card contacts require cleaning: Clean the contacts with a soft, dry cloth. If the message is repeated, format the card. If the message persists, replace the card. • Camera malfunction: Contact a Fujifilm dealer.

Warning	Description
PROTECTED FRAME	An attempt was made to delete a protected picture. Remove protection and try again.
CAN NOT CROP	The picture is damaged or was not created with the camera.
DPOF FILE ERROR	Print orders can contain no more than 999 pictures. Copy any additional pictures you wish to print to another memory card and create a second print order.
CAN NOT ROTATE	<ul style="list-style-type: none"> • Pictures taken with other cameras cannot be rotated. • An attempt was made to rotate a protected picture. Remove protection and try again.
 CAN NOT ROTATE	Movies cannot be rotated.
CAN NOT SET DPOF	The picture cannot be printed using DPOF.
 CAN NOT SET DPOF	Movies cannot be printed using DPOF.
 CANNOT EXECUTE	Red-eye removal cannot be applied to movies.
 CANNOT EXECUTE	Red-eye removal cannot be applied to pictures created with other devices.
	Turn the camera off and wait for it to cool. Mottling may increase in pictures taken when this warning is displayed.

Memory Card Capacity

The following table shows the recording time or number of pictures available at different image sizes. All figures are approximate; file size varies with the scene recorded, producing wide variations in the number of files that can be stored. The number of exposures or length remaining may not diminish at an even rate.

		Capacity		8 GB		16 GB	
		FINE	NORMAL	FINE	NORMAL		
Photos	 16:9	660	1060	1330	2120		
	RAW (UNCOMPRESSED)	180		370			
	 29.97P, 25P, 24P, 23.98P ²	9 minutes		20 minutes			
Movies ¹	 59.94P, 50P, 29.97P, 25P, 24P, 23.98P ³	26 minutes		54 minutes			
	 59.94P, 50P, 29.97P, 25P, 24P, 23.98P ³	51 minutes		105 minutes			
	 59.94P, 50P, 29.97P, 25P, 24P, 23.98P ³	51 minutes		105 minutes			
	 59.94P, 50P, 29.97P, 25P, 24P, 23.98P ³	51 minutes		105 minutes			

1 Use a UHS speed class 3 card or better.

2 Individual movies cannot exceed 15 minutes in length.

3 Individual movies cannot exceed 30 minutes in length.

 Although movie recording will continue without interruption when the file size reaches 4GB, subsequent footage will be recorded to a separate file which must be viewed separately.







Temperature Warnings

The camera automatically turns off to protect itself when its temperature or the temperature of the battery rises. If a temperature warning is displayed, image noise may increase. Turn the camera off and wait for it to cool before turning it on again (📖 242).

Specifications

System		
Model	FUJIFILM X-T200	
Product Number	FF190004	
Effective pixels (3:2)	Approx. 24.2 million	
Image sensor	23.5 mm × 15.7 mm (APS-C format), CMOS (complementary metal-oxide semiconductor) image sensor with square pixels and primary color filter	
Storage media	Fujifilm-recommended SD/SDHC/SDXC memory cards	
Memory card slots	SD memory card slot (UHS-1)	
File system	Compliant with Design Rule for Camera File System (DCF), Exif 2.3, and Digital Print Order Format (DPOF)	
File format	<ul style="list-style-type: none">• Still pictures: Exif 2.3 JPEG (compressed); RAW (original RAF format, special purpose software required); RAW+JPEG available• Movies: H.264 standard with stereo sound (MPEG-4)	
Image size	L 4:3 (5328 × 4000)	L 3:2 (6000 × 4000)
	M 4:3 (3712 × 2784)	M 3:2 (4240 × 2832)
	S 4:3 (2656 × 1992)	S 3:2 (3008 × 2000)
	L 16:9 (6000 × 3376)	L 1:1 (4000 × 4000)
	M 16:9 (4240 × 2384)	M 1:1 (2832 × 2832)
	S 16:9 (3008 × 1688)	S 1:1 (2000 × 2000)
	RAW (6000 × 4000)	
	L panorama: vertical (2160 × 9600)/horizontal (9600 × 1440)	
	M panorama: vertical (2160 × 6400)/horizontal (6400 × 1440)	
	Lens mount	FUJIFILM X mount
Sensitivity	<ul style="list-style-type: none">• Still pictures: Standard output sensitivity equivalent to ISO 200–12800 in increments of 1/3 EV; AUTO; extended output sensitivity equivalent to ISO 100, 25600, or 51200• Movies: Standard output sensitivity equivalent to ISO 400–6400 in increments of 1/3 EV; AUTO	
Metering	256-segment through-the-lens (TTL) metering; MULTI, SPOT, AVERAGE	
Exposure control	Programmed AE (with program shift); shutter-priority AE; aperture-priority AE; manual exposure	
Exposure compensation	<ul style="list-style-type: none">• Still pictures: –5 EV–+5 EV in increments of 1/3 EV• Movies: –2 EV–+2 EV in increments of 1/3 EV	

System

Shutter speed	<ul style="list-style-type: none"> • Mechanical shutter <ul style="list-style-type: none"> - Mode P: 4 s to $\frac{1}{4000}$ s - Other modes: 30 s to $\frac{1}{4000}$ s - Bulb: Max. 60 min. • Mechanical+electronic <ul style="list-style-type: none"> - Mode P: 4 s to $\frac{1}{32000}$ s - Other modes: 30 s to $\frac{1}{32000}$ s - Bulb: Max. 60 min. 	<ul style="list-style-type: none"> • Electronic shutter <ul style="list-style-type: none"> - Mode P: 4 s to $\frac{1}{32000}$ s - Other modes: 30 s to $\frac{1}{32000}$ s 									
Continuous (16:9)	<table border="1"> <thead> <tr> <th>Mode</th> <th>Frame rate (fps)</th> <th>Frames per burst</th> </tr> </thead> <tbody> <tr> <td></td> <td>8.0</td> <td>Up to approximately 20</td> </tr> <tr> <td></td> <td>4.0</td> <td>Up to approximately 50</td> </tr> </tbody> </table>	Mode	Frame rate (fps)	Frames per burst		8.0	Up to approximately 20		4.0	Up to approximately 50	
	Mode	Frame rate (fps)	Frames per burst								
	8.0	Up to approximately 20									
	4.0	Up to approximately 50									
<p> The frame rate varies with shooting conditions and the number of images recorded. In addition, the frame rate and number of frames per burst may vary depending on the type of memory card used.</p>											
Focus	<ul style="list-style-type: none"> • Focus-area selection: SINGLE POINT, ZONE, WIDE/TRACKING • Mode: Single or continuous AF; manual focus with focus ring; AF+MF • Autofocus system: Intelligent hybrid AF (TTL contrast-detect/phase-detection AF) with AF-assist illuminator 										
White balance	Custom, color temperature selection, auto, direct sunlight, shade, daylight fluorescent, warm white fluorescent, cool white fluorescent, incandescent, underwater										
Self-timer	Off, 2 sec., 10 sec., Face auto shutter, Smile, Buddy, Group										
Flash	<ul style="list-style-type: none"> • Type: Manual pop-up flash unit • Guide number: Approx. 7/23 (ISO 200, m/ft.), 5/16 (ISO 100, m/ft.) 										
Flash mode	Auto, fill flash, off, slow sync, rear-curtain sync, commander (red-eye removal off); auto with red-eye removal, fill flash with red-eye removal, off, slow sync with red-eye removal, rear-curtain sync with red-eye removal, commander (red-eye removal on)										

System

Hot shoe	Accessory shoe with TTL contacts
Sync contact	X contact; supports sync speeds as fast as $\frac{1}{180}$ s
Sync terminal	—
Electronic viewfinder (EVF)	0.39-in., 2360k-dot OLED viewfinder; magnification 0.62× with 50 mm lens (35 mm format equivalent) at infinity and diopter set to -1.0 m ⁻¹ ; diagonal angle of view approximately 30° (horizontal angle of view approximately 25°) <ul style="list-style-type: none">• Diopter adjustment: -4 to $+2$ m⁻¹• Eyepoint: Approximately 17.5 mm
LCD monitor	Fixed 3.5-in./8.9 cm, 2760k-dot color touch screen LCD monitor, Vari-angle LCD monitor

Movies

• Movies with stereo sound

29.97P	59.94P	59.94P
25P	50P	50P
24P	29.97P	29.97P
23.98P	25P	25P
	24P	24P
	23.98P	23.98P
	59.94P	59.94P
	50P	50P
	29.97P	29.97P
	25P	25P
	24P	24P
	23.98P	23.98P

• Silent HD high-speed movies

2× 59.94P 120P	2× 50P 100P
4× 29.97P 120P	4× 25P 100P
5× 24P 120P	5× 23.98P 120P

Input/output terminals

Digital input/output	USB3.1Gen1 USB connector (Type-C)
HDMI output	HDMI Micro connector (Type D)
Microphone/remote release connector	ø3.5 mm 3-pole mini jack

Power supply/other

Power supply	NP-W126S rechargeable battery
Camera size (W × H × D)	121.0 mm × 83.7 mm × 55.1 mm (34.7 mm excluding projections, measured at thinnest part)/4.8 in. × 3.3 in. × 2.2 in. (1.4 in.)
Camera weight	Approx. 321 g/11.3 oz., excluding battery, accessories, and memory card
Shooting weight	Approx. 370 g/13.1 oz., including battery and memory card
Operating conditions	<ul style="list-style-type: none"> • Temperature: 0 °C to +40 °C/+32 °F to +104 °F • Humidity: 10% to 80% (no condensation)
Battery life	<ul style="list-style-type: none"> • Battery type: NP-W126S • Lens: XF35mmF1.4 R • Shooting mode: Mode P

Approximate number of frames		
	STANDARD	ECONOMY
	270	450
Mode	Actual Battery life of movie capture	Continuance Battery life of movie capture
4K	Approx. 55 minutes	Approx. 80 minutes
FHD	Approx. 60 minutes	Approx. 95 minutes

CIPA standard, measured using battery supplied with camera and SD memory card.

Note: Number of shots that can be taken with battery varies with battery charge level and will decline at low temperatures.

Wireless transmitter

Wireless LAN

Standards	IEEE 802.11b/g/n (standard wireless protocol)
Operating frequency (center frequency)	<ul style="list-style-type: none">• Japan, China: 2,412 MHz–2,472 MHz (13 channels)• Other countries: 2,412 MHz–2,462 MHz (11 channels)
Access protocols	Infrastructure

Bluetooth®

Standards	Bluetooth version 4.2 (Bluetooth Low Energy)
Operating frequency (center frequency)	2,402 MHz–2,480 MHz

NP-W126S rechargeable battery

Nominal voltage	7.2 V DC
Nominal capacity	1,260 mAh
Rating capacity	1,200 mAh
Operating temperature	0 °C to +40 °C/+32 °F to +104 °F
Dimensions (W × H × D)	36.4 mm × 47.1 mm × 15.7 mm/1.4 in. × 1.8 in. × 0.6 in.
Weight	Approx. 47 g/1.7 oz.

Weight and dimensions vary with the country or region of sale. Labels, menus, and other displays may differ from those on the actual camera.

 Specifications and performance are subject to change without notice. Fujifilm will not be held liable for any errors this manual may contain. The appearance of the product may differ from that described in this manual.

